

FS-8000

Digital
Weighing Indicator

INSTRUCTION MANUAL

CONTENTS

CHAPTER 1. PREFACE	
1-1	INTRODUCE.....3
1-2	SAFTY CONDITIONS..... 3
1-3	FEATURES..... 4
1-4	FRONT PANEL DESCRIPTION..... 5
1-4-1	LAMP..... 5
1-4-2	HOW TO USE KEY..... 6
1-5	REAR-SIDE PANEL..... 9
1-6	SPECIFICATION..... 11
1-7	THE EXAMPLE FOR THE CONNECTING TO EXTERNAL DEVICES..... 12
CHAPTER 2. INSTALLATION.....	13
2-1	OUT-DIMMENSION & CUTTING SIZE... 14
2-2	ASSEMBLE DRAWING.....15
2-3	HOW TO CONNECT LOADCELL..... 16
2-4	ERROR & A/S..... 17
CHAPTER 3. CALIBRATION.....	18
3-1	ZERO ADJUSTMENT..... 18
3-2	SPAN CALIBRATION.....20
3-3	ERROR MESSAGES & ADJUST..... 24
CHAPTER 4. SET-UP.....	27
4-1	PREFACE.....27
4-2	SET-UP..... 27
4-3	F-FUNCTION SUMMARY LIST..... 29
CHAPTER 5. SET-UP ILLUSTRATION.....	30
5-1	BASIC FUNCTION FOR WEIGHING..... 30
5-2	BASIC FUNCTION FOR DEVICES..... 32
5-3	SERIAL INTERFACE37
5-3-1	RS-232C SERIAL INTERFACE..... 38
5-3-2	OP-02 CURRENT LOOP..... 40
5-4	ADDITIONAL SET UP FUNCTION..... 42
5-4-1	OP-03 BCD OUT..... 42
5-4-2	OP-04 RS-422/485 SERIAL 44
5-4-3	OP-05/06 ANALOG OUT..... 45
5-4-4	OP-07 PRINTER..... 48
5-4-5	OP-10 BCD INPUT..... 50

CHAPTER 1. PREFACE

1-1. INTRODUCE

Thank you very much for your purchasing FINE Digital Weighing Indicator of **FS-8000**.

This Instruction Manual will make you lead to use **FS-8000** with FINE speed,accuracy,reliability.

FS-8000 is designed to withstand harsh environmental conditions and is designed for flawless Performance in your demanding application.

Also,FS-8000 have several options that is both versatile and easily connectable to other devices.

APPLICATION

1. PACKING EQUIPMENTS FOR MANUAL WEIGHING
2. EQUIPMENTS FOR PLATFORM,TANK,TRUCK SCALE
3. EQUIPMENTS FOR STRAIN/COMPRESSION TESTER
4. RECORD-MANAGEMENT FOR PRODUCT WEIGHT

REMARK

- This Specification is subjected to change for improvement without prior notice.
- This Version Number will be increased as it graded up.

1-2. SAFTY CONDITIONS

Please keep the following conditions for safe environment.

EARTH

To avoid an electric error such as a noise,electrostatics in your production line

It certainly should be earthed before installation

Specially in case of thunderbolt,it had better devide the power of Indicator into a load cell.

SAFTY CONDITIONS

Don`t use it at the environment close to a explosive gas and an inflammable dust environments

POWER

Use the power under 110/220V 50/60HZ \pm 10% and devide it into the power line

TEMPERTURE CONDITIONS

OPERATING TEMPERTURE : -10° C +40° C (+14° to 104° F)

CUSTODY TEMPERTURE : -40° C +80° C (-40° to 176° F)

INSTALLATION LOAD CELL

- Available to use Max.8pcs of the same Load cell of (300 criterion)
- It should be horizontal to ground
- In case of Installing over 2pcs of load cell,Connect each line in parallel and Insert a precise variable resistor under 50 in EX + line.
And minimize a output deviation of a load cell.
It may occur a weight error according to several deviation of a load cell.
- It may occur a weight error according to a temperature variation of load cell
- Please don't weld(electrospark) at the place where a load cell and equipments were installed,
However,Please divide the power into a connector of load cell in inevitable case
- Please connect the above and below construction of a load cell to the weighing part
Weighing a products electrosparks may be occurred.

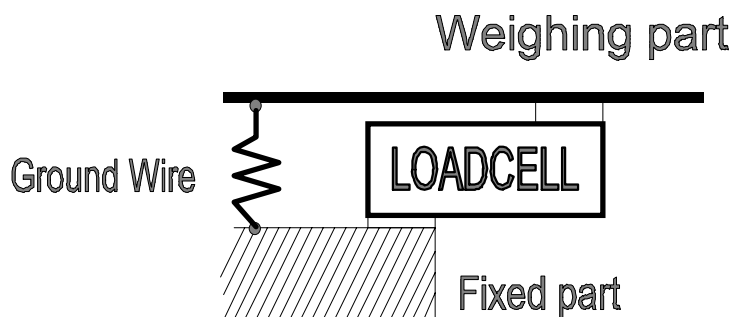

1-3. FEATURES

- A compact Appearance by DIN regulations (DIN 192 x 96 Panel Insertion)
- Easy to set up, change,confirm several values by the numeral key.
- Improved a convenience and precision of operating by Message Function.
- Can display a various information by F1,F2,F3 key for the end-user.
- Can make several key function use or disuse.(**SETUP F10 Reference**)
- Back up of Weight even electrospark case (**SETUP F02 Reference**)
- The permit or prohibition function of Calibration (**ADJUST NO 10 Switch**)
- **Watch-Dog** timer guards for self-diagnostics.
- Set up to Max. 1/20,000 display resolution
- Function available to change the unit value such as **kg, ton, lb ,g**
(In case of Serial Interface & Printer)
- Available to change the function of the external input terminal (**SETUP F16 Reference**)
- Various option Functions for customer`s satisfaction such as **RS-422/485, Current Loop, Analog out, BCD Input/Output and so on.**
- **RS-232C Serial Interface & Printer was installed basically**
- **Available to print by either Serial Interface or Centronics Parallel Interface**

1-4. FRONT PANEL DESCRIPTION

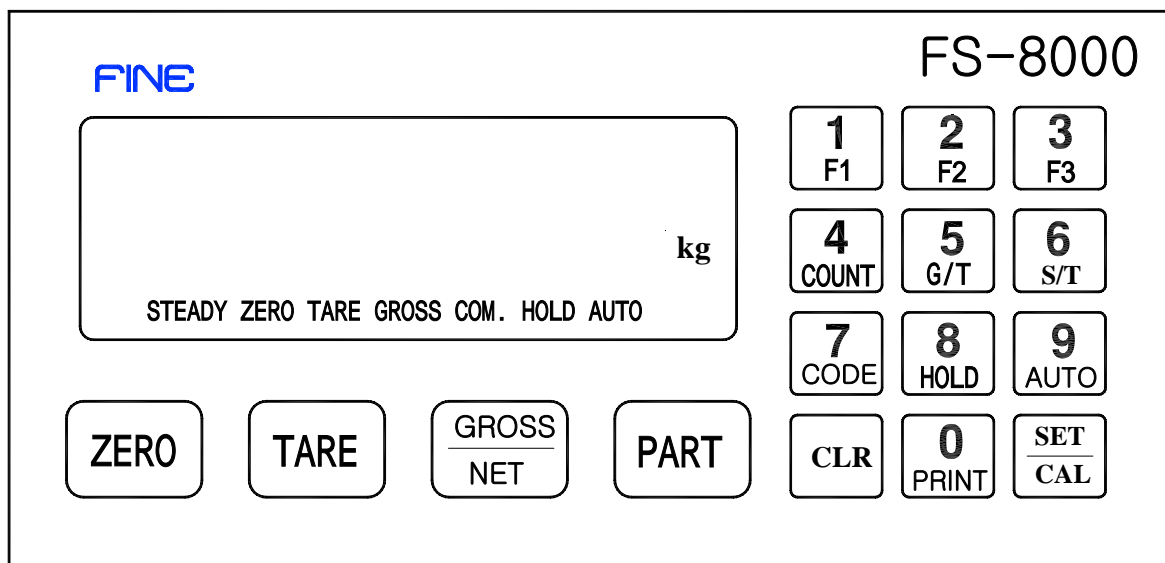

1-4-1. LAMP

- STEADY** : This Lamp will be turned on the stable weight
The condition of STEADY Lamp can set up by F04,F08.
Also,it will be a certerion of weighing for auto function operating.
- ZERO** : This Lamp will be truned when the weighing device is empty.
The condition of ZERO Lamp can set up by F03,F13.
Also,it will be a certerion of weighing for auto function operating.
- TARE** : This Lamp will be displayed when TARE weight was set up
(SET-UP F12 REFERENCE)
- GROSS** : This Lamp will be displayed when the present weight was GROSS.
Avalible to display When TARE was set up.
- COM.** : This Lamp will be displayed when Serial Interface was connected to
External devices
- HOLD** : This Lamp will be displayed when HOLD works (SETUP F25 REFERENCE)
- AUTO** : This Lamp will be displayed when AUTO works (SETUP F24 REFERENCE)

1-4-2. HOW TO USE KEY

*** The Key operating can be permitted or prohibited by SETUP-F10**

*** When pushing the key,it sounds "OK".**

*** Several Key works either a single function or compound functions.**

A compound function key is the command key when it push first and

In case of setting value according to the command key,then the numeral Key works.

Finally The key to finish a input data is **SET Key**.

* The time to input a data by compound key is limited to 5sec and automatically
Will be removed without the next key inputting.

ZERO Key : This key is to return to ZERO when the weighing device is empty(the end-user
Selected within 2%, 10%, 50%, 90% by SET-UP F07)

TARE Key : The way to set-up the tare weight is two way as follows.

Manual Way

1.Set-up of TARE Key

Put a TARE on the weighing plate

TARE Key SET Key OR TARE Key Numeral Key SET Key

2.Remove of TARE Key

Remove TARE on the weighing plate

Push TARE Key and push SET Key.

Automatic Way

1.Auto-TARE setting if TARE was on the weighing plate

2.Auto-TARE setting after putting TARE and Auto-TARE Remove

After Taking away TARE on the weighing plate.

Please refer to SETUP F12

Gross/Net Key : After setting TARE,This key is to convert Net Weight to Gross Weight
And Gross Weight to Net Weight.

* Available to convert TARE setting only

* Gross Lamp turn on when Gorss Mode works.

PART Key : Usable to confirm or change the product part

* Can set up the data of each product from 1 No to 20 No.

- Checking PART : **PART Key** **CLR Key**

- Changing PART : **PART Key** Numeral Key SET key

F1,F2,F3 Key : This keys appear a various data as the end-user demands.
Available to use the end-user demanding by SETUP F21,F22,F23
(SET UP F21 REFERENCE)

COUNT Key : This Key appears the worked frequency of each PART.
* Unavailable to change the PART deliberately.

G/T KEY : The function to print The weight of Gross Total
* Avavailable to remove Gross Total in printing.

S/T KEY : The function to print The weight of Sub Total.
* Available to remove Sub Total in printing

CODE KEY: The function to check and set Max.6figure CODE of Each PART.
* Checking CODE.
: CODE key Checking CLR(Remove)
* Change or setting CODE.
: CODE key Inputting changed Key SET(Change or setting)

HOLD Key : This key is to set/delete HOLD Functions.
* Possible to choose various functions by SET UP F25.
- Manual HOLD : Holding the moment weight value by HOLD **Key**
- Manaul HOLD(Average) : Holding Average weight value after pushing HOLD Key
- A stable hold : Holding the weight value when being stable
- Maxium HOLD(1Time only) : Holding the maxium weight value when being maxium
- Maxium HOLD (Continue) : Holding a continuous maxium weight
When being new maxium

AUTO Key : This key is to set/delete AUTO Function.
* Possible to choose various functions by SET UP F24.
- Auto-totallization in holding the weight.
- Available to work the HOLD function by AUTO setting Only.
- Available to work the HOLD function by AUTO setting Only
And to remove the HOLD function when it empty.
- Auto-totallization when the weight is safty
* Possible to choose AUTO/MANUAL by SET UP F19 when the power is ON.

PRINT Key : This Key is to Transmit, Totalize, Print a DATA

* Unavailable to work it while Auto Mode

* Please push **CLR + Print when deleting the last TOTAL date.**

Only Unavailable to re-power, change the PART, Available 1 time only

(The last total data will be deleted also on Auto-total)

CLR Key : This have 4 way to use as follows .

1) When cancelling it with inputing the setting value

2) **CLR + TOTAL(+TOTAL) +SET** When setting the total data.

3) **CLR + Print when deleting the last TOTAL date**

4) When using SETUP or CALIBRATION (3Chapter, 4Chapter REFERENCE)

* After CLR Key, If no a additional data, it will be deleted automatically. .

SET/CAL Key : **SET** key have 2 way to use as follows

1) When recording each setted data

2) When using SETUP or CALIBRATION(3Chapter, 4Chapter REFERENCE)

1-5. REAR-SIDE PANEL

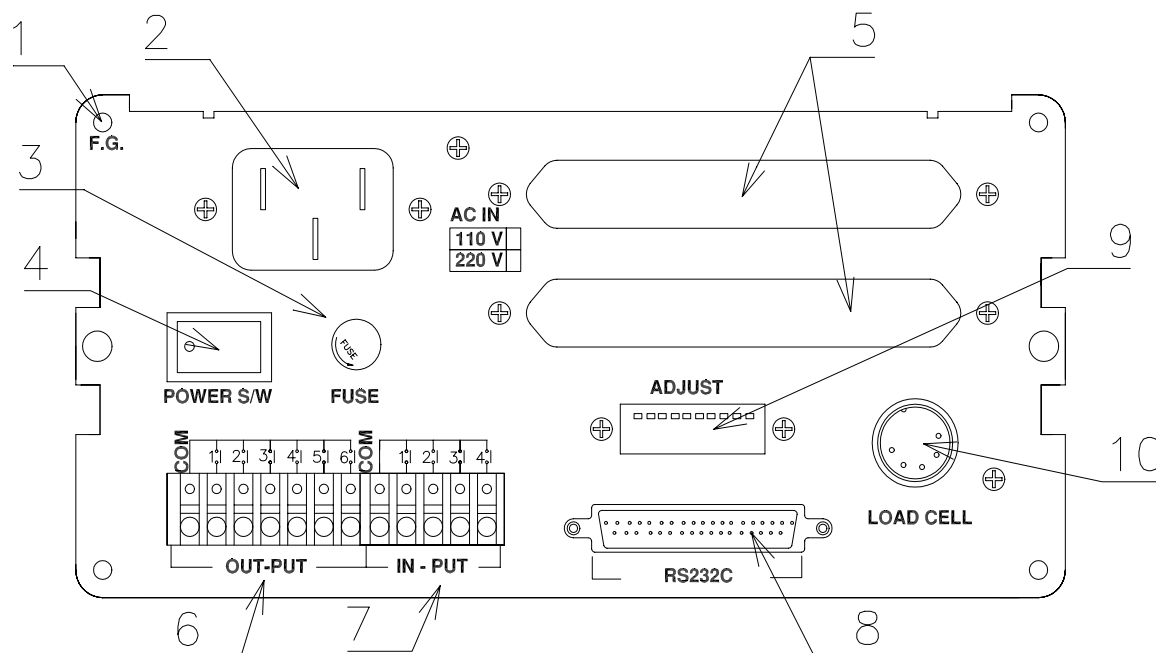

1. F.G. : Please earth it for safe.

2. AC IN : Available to change AC110/220V with multiple.

Before setting up, please confirm the power voltage.

Please change the connect terminal of 110V/220V after opening the cover

If you need to change. (It was setted with AC220V at the first)

3. FUSE : please use the standard approved .

(FUSE) AC250V, 0.3A (a glass tube with small type)

4. POWER S/W) ON/OFF

It will be safe to use it after 10minuate for a precise measurements

5. DATA OUT (OPTION BOARD) :

Serial Communication.RS422, BCD OUTPUT, Analog Voltage,

Electric Currnet(Analog Out) 0-10V or 4-20mA, Print Out

6. OUT-PUT : Connect between COM terminal and OUTPUT terminal

With the earth of no electric power, please use the output data

For a signal only, don't use it for working.

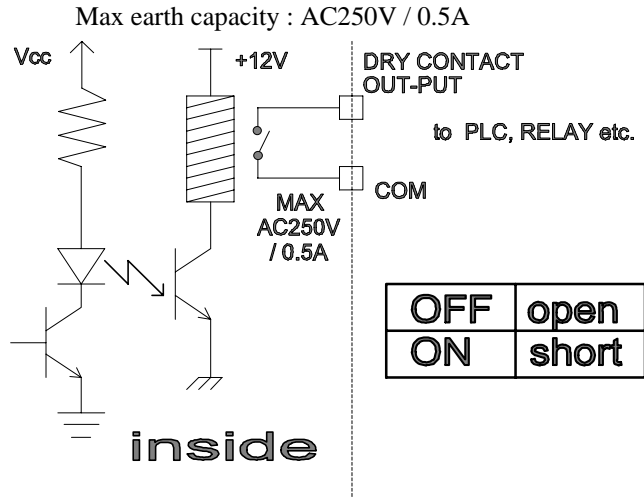

7. IN-PUT : This key is to control a equipment from the outside .

The functions of input terminal is to choose it by SETUP F16

Please connect between COM terminal and each input terminal .

Because the power of input terminal was connected with 12V voltage From the inside.

* An electric current is about **10mA**.

* Please make the Minium time to input a data with over **50mSEC**.

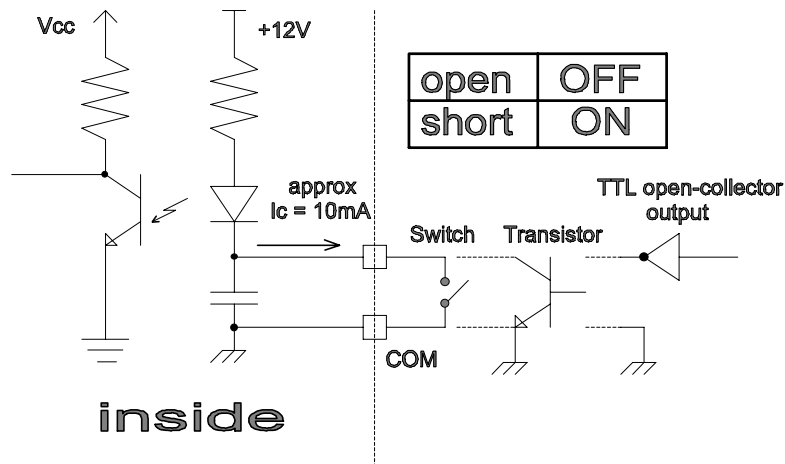

8. RS-232C (25P D-type Female) : (OP-01)

9. Loadcell Connector(N-16)

- ① EX+ (+5V) ② EX- (-5V) ③ SIG+
- ④ SIG- ⑤ SHIELD

10. ADJUST : DIP Switch for ZERO and SPAN Control

(1-6No : ZERO , 7-8No : SPAN , 10No : Calibration Lock

Functions of each input terminal is to choose SETUP F16.

1-6. SPECIFICATION

1. Analog Input & A/D Conversion

Input Sensitivity	0.2 μ V/D
ZERO adustment Range	-4mV 42.0mV
Load cell excitation	DC 10V (\pm 5 V)
Max Input voltage	32mV
Temperature Coefficient	\pm 20 ppm /
INPUT Noise	\pm 0.5 μ V P.P
INPUT Impedance	10 M Ω (MAX)
A/D Converter	130,000 Count
Non-Linearity	0.005% F.S

2. DIGITAL SECTION

MAX.DISPLAY	"1000000"
MIN.DIVISION	x1, x2, x5, x10, x20, x50
DISPLAY UNIT	7-Segment, 7digit Highly bright fluorescent tube
KEY BOARD	Numerical Key and Function Key(0-9,CLR,SET/CLR)
Data Back-up	APPR.10 YEAR

3. GENERAL

POWER	AC110 / 220V (\pm 10%). 50 / 60Hz. 10VA
PRODUCT WEIGHT	NET 2.3kg BOX 3.3kg
Operating Temperature	-10 40
Operating Humidity	85%RH MAX (Non-Condensing)
Physcal Dimmensions	193.6 x 98 x 166 (mm)

4. OPTION

OP-01	STANDARD
OP-02	Serial I/F : CURRENT LOOP
OP-03	Parallel I/F : BCD Out
OP-04	Serial I/F : RS422, RS485
OP-05	Analog Output : Vout (0-10V / 10V-0V)
OP-06	Analog Output : Iout (4-20mA / 20-4mA)
OP-07	Print I/F : CENTRONICS Parallel
OP-10	Parallel I/F : BCD In PART

1-7. The example for the connecting To external devices

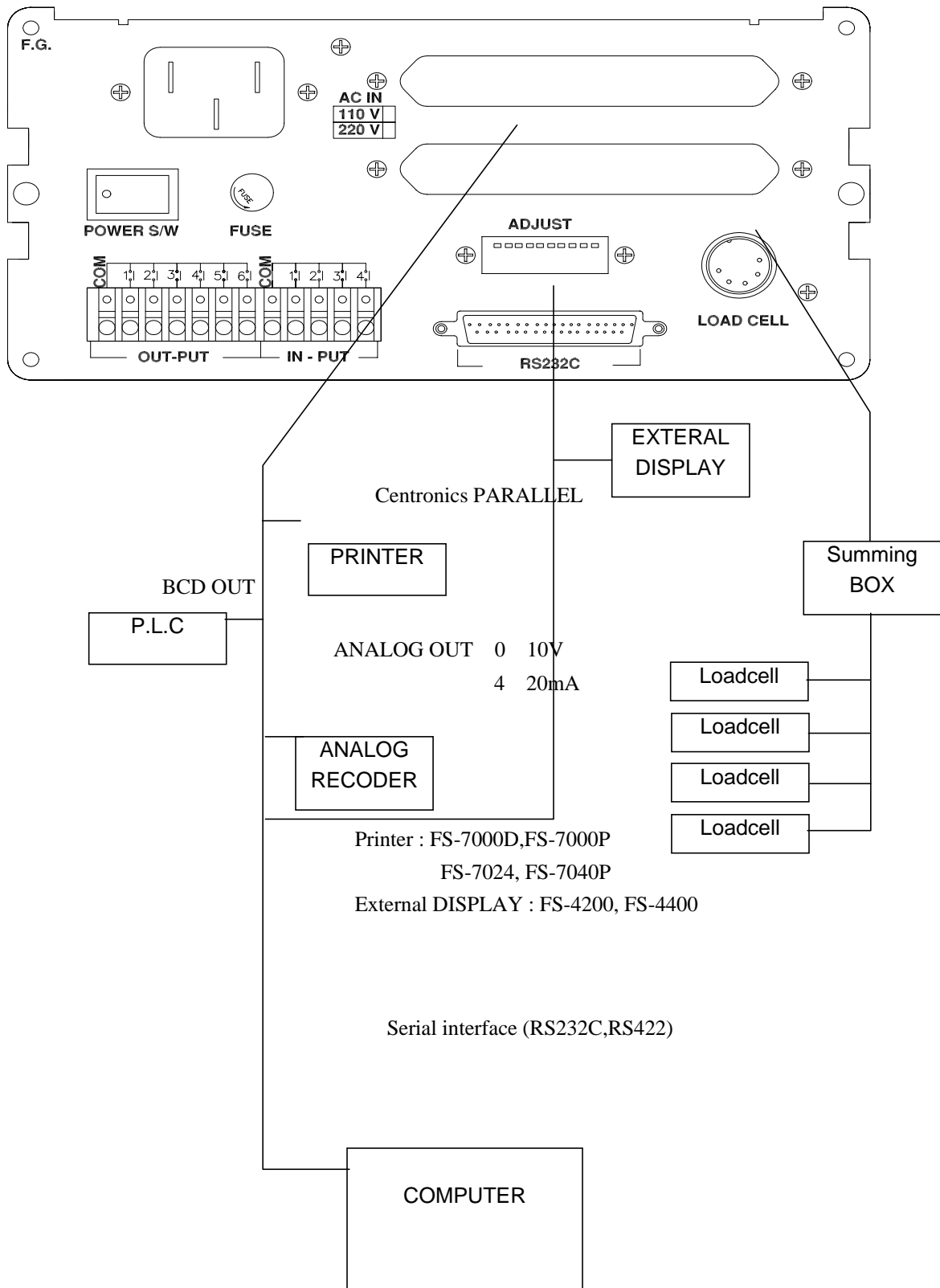

CHAPTER 2. INSTALLATION

GENERAL RULES

- **Avoid sudden Collision,vibration.temperature.water,wind**
- Use a stable power supply 110V/220V \pm 10% 50/60Hz - Set up voltage **220V**
(Adjust the power voltage because the choice terminal of power is inside.)
- **Connect and power off the switch when connecting the external equipments.**
- Make ensure to earth Indicator to equipments
- Make ensure to calibrate and set up it for operating.

* PARTS

- POWER CODE : 1EA
- FUSE : 2EA (PIPE TYPE 250V 0.3A SMALL TYPE)
- LOAD CELL CONNECTOR : 1EA (N16-05)
- OPERATING MANUAL : 1EA
- A Stable Connector for Option installation.

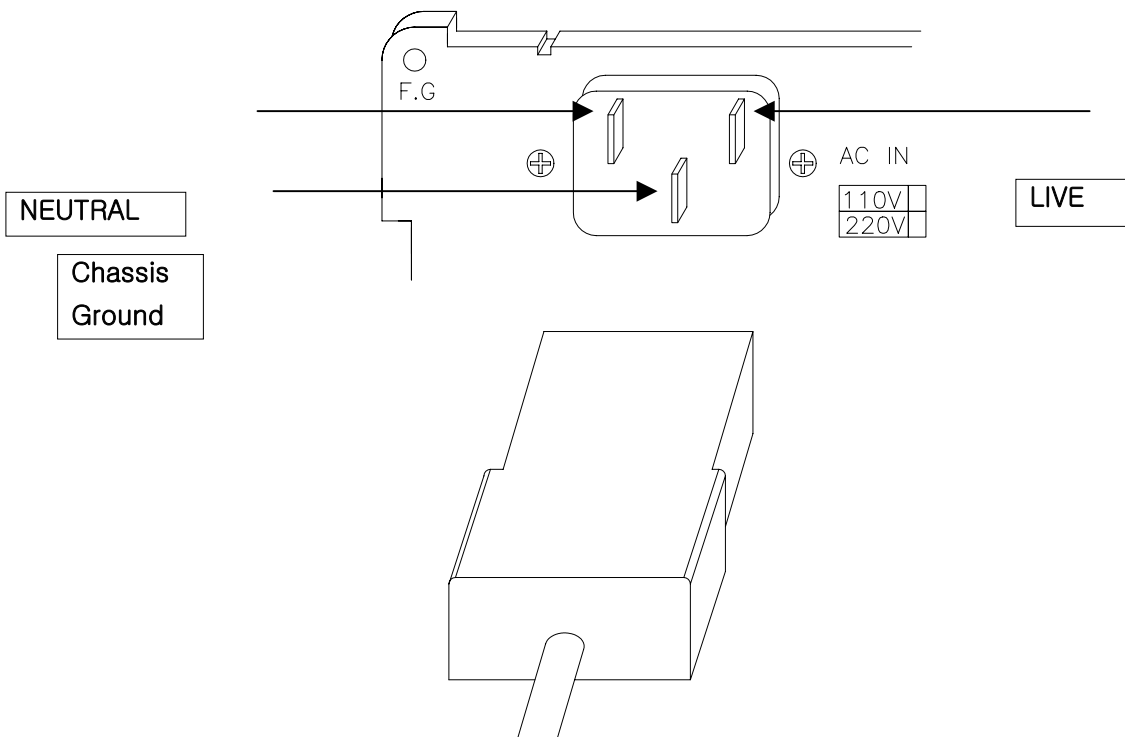

The connection of power cable

2-1.Out-Dimmmension & CUTTING SIZE

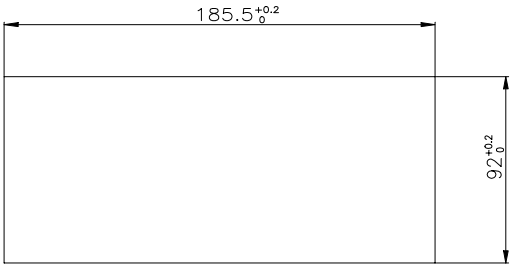
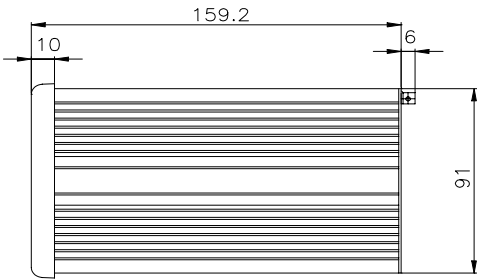
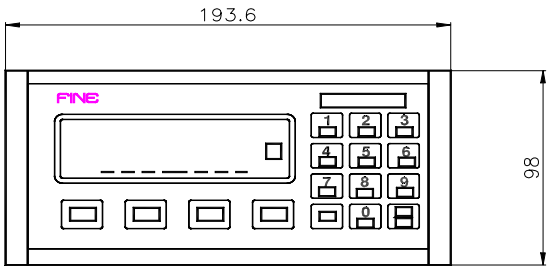
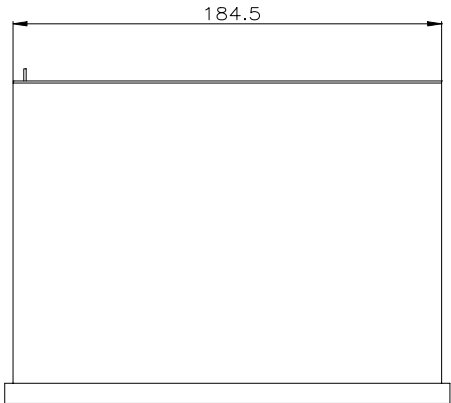

2-2. ASSEMBLE DRAWING

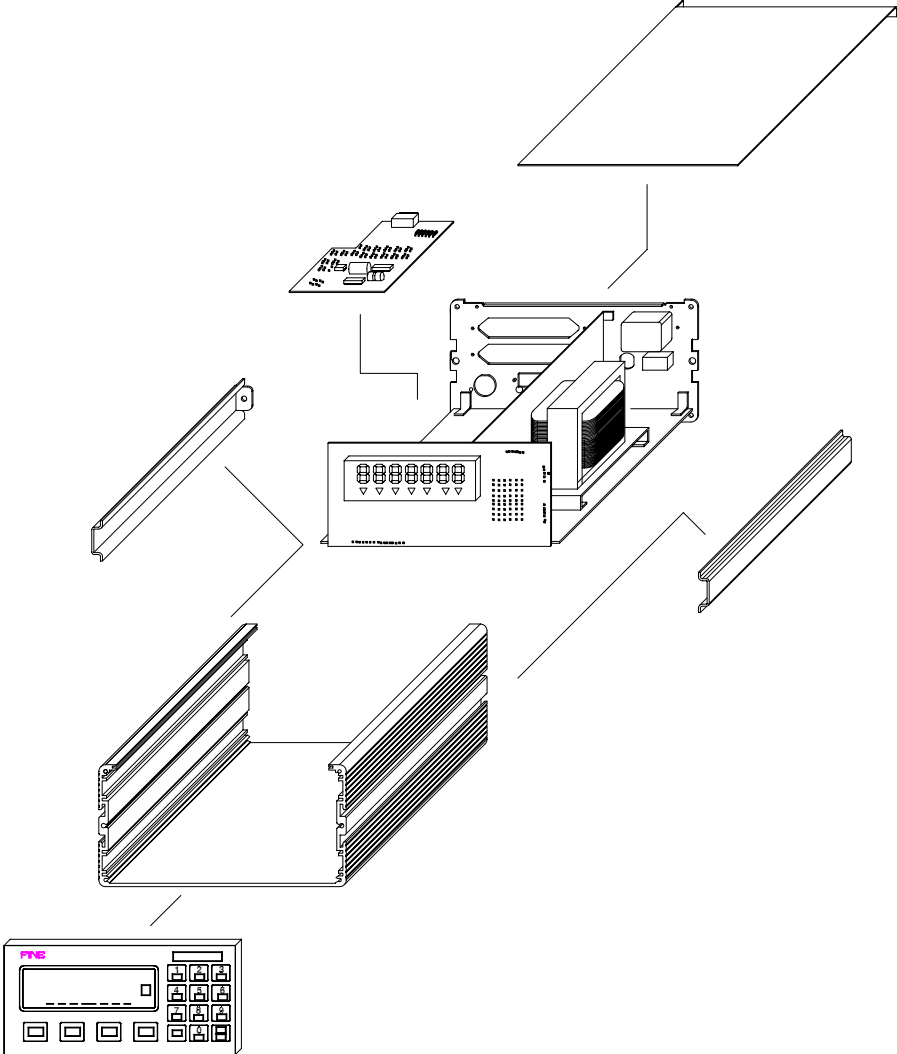

2-3.HOW TO CONNECT LOAD CELL

1. STABLE LOAD CELL

The output power of load cell which was used as a weight sensor is $1mV/V$ $3mV/V$

The output voltage of load cell is not absolute value but relative value.

Ex) if Max weight was loaded to 10kg & 10ton load cell of $3mV/V$ output,
The Output Voltage is the same as $3mV/V$

2. Load cell Connector

* Please connect the indicator connector with the wire of load cell
According to the color.

*Possible to connect the load cell of the same kind in parallel up to 8pcs.(Max 300)



3. The wire color of load cell according to a manufacturer.

	1 EXC+	2 EXC-	3 SIG+	4 SIG-	5 SHLD	비고
FINE INDICATOR`S WIRE COLOR	RED	WHITE	GREEN	BLUE	SHIELD	
BONGSHIN, CAS, TMI, AND DAESUNG LOAD CELL	RED	WHITE	GREEN	BLUE	SHIELD	
JUNGSAN	RED	BLACK	WHITE	GREEN	SHIELD	
DAISOCELL	RED	BLUE	GREEN	WHITE	BLACK	
DANA	RED	WHITE	GREEN	BLUE	SHIELD	
BLH	GREEN	BLACK	WHITE	RED	YELLOW	
INTERFACE	RED	BLACK	GREEN	WHITE	SHIELD	
KYOWA	RED	BLACK	GREEN	WHITE	SHLED	
P.T.	RED	BLACK	GREEN	WHITE	SHIELD	
SHOWA	RED	BLUE	WHITE	BLACK	SHIELD	
SHINKOH	RED	BLACK	GREEN	WHITE	SHIELD	
TML	RED	BLACK	WHITE	GREEN	SHIELD	
TEAC	RED	BLUE	WHITE	BLACK	YELLOW	
HUNTLEIGH	GREEN	BLACK	RED	WHITE	SHIELD	

Load cell Connector Standard : N16-05

Because Wire color may be different according to a manufacturer and load cell models.

Please refer for the data sheet of load cell.

2-4. ERROR & A/S

ERROR	CAUSE	A/S	Reference.
Waving a weight Value.	<ul style="list-style-type: none"> ① Load cell damage ② Insulation resistance badness of load cell. ③ Weighing part error 	<ul style="list-style-type: none"> ① Checking for Input, Output of loadcell. Resistance Value. ② Checking Insulation Resistance value of Load cell. 	<ul style="list-style-type: none"> ① Input resistance : about 420 ② Output resistance : about 350 ③ Insulation Resistance : over100M
A. Changing a Weight value, B. Not return to ZERO	① Load cell damage.	<ul style="list-style-type: none"> ① Checking Insulation Resistance value of Load cell. (Normal Max 100M or -OL-appear) 	
	① Disconncted to Load Cell.	<ul style="list-style-type: none"> ① Confirm a connect of Load cell ② Checking a single wire Of load cell cable 	
Weight (-) changed	① Load cell output (SIG+,SIG-)changed.	① Load cell connector	ERR-55 occurrence
Appear "bAd" on self-diagnosis	① Disconnect to Load Cell Damage	<ul style="list-style-type: none"> ① Load cell damage ② Load cell connector 	
	① Excess a range of Zero value.	① Zero adjustment. (5000-15000)	
Appear "UL" (UNDER LOAD)	① Load cell damage. Disconnect to Indicator.	<ul style="list-style-type: none"> ① Load cell damage ② Load cell connector 	
	① ZERO adjustment.	① Zero adjustment. (5000-15000)	
Appear "OL" (OVER LOAD)	<ul style="list-style-type: none"> ① Load cell damage ② Connection Error 	<ul style="list-style-type: none"> ① Load cell damage ② Load cell connector 	
	① Excess Max weight	① Remove excess weight	

CHAPTER 3.CALIBRATION

What is Calibration?

Calibration is to adjust Max.weight,minium division,decimal point displayed to Indicator To the actual weight worked by load cell.

It should calibrated certainly when load cell or indicator will be changed.

3-1. ZERO ADJUSTMENT

What is zero adjustment.?

The meaning of ZERO is the fiducial point of weighing operation.

In case a zero value is less than normal operating zero range,

The indicator will be displayed to **"UL"**.

The other side, it will be displayed to **"bAd"**.

Then,it will be not operated normally

ZERO POINT RANGE

Adjust the value displayed to **"test1"** closed to 1000 - 20000 (Recommand5000)

(Dip-switch 1-6)

ZERO POINT ADJUSTMENT REFERENCE AS FOLLOWS

1. HOW TO ADJUST ZERO POINT

Please turn on while pushing **⓪key** after turn off

The display was displayed as follows

tES _t

Push **⓪key** again,Indicator displays zero value after displaying **"test1"**

Then,if an zero value was not displayed or displayed with **"test1"** only

Or not Displayed any number,Turn on the dip-switch(1~6)of the real panel,

Adjust the dip-switch that The number appearing on the display should be closed to 5000.

(Example)

While pushing ⓪key + Power turn on -> tES_t

While displaying tES_t +⓪key,puse ⓪key again.

Then this value will be zero value.

2. How to adjust a dip-switch.(Adjust at the real panel.)

	Wide range change						a multiple of zero adjustment	changed range
	1	2	3	4	5	6		
1	ON	ON	ON	ON	ON	ON	0	0
2	OFF	ON	ON	ON	ON	ON	1	-980 changed range
3	ON	OFF	ON	ON	ON	ON	2	-1960 changed range
4	OFF	OFF	ON	ON	ON	ON	3	-2940 changed range
5	ON	ON	OFF	ON	ON	ON	4	-3920 changed range
:	:	:	:	:	:	:		
62	OFF	ON	OFF	OFF	OFF	OFF	61	-59780 changed range
63	ON	OFF	OFF	OFF	OFF	OFF	62	-60760 changed range
64	OFF	OFF	OFF	OFF	OFF	OFF	63	-61740 changed range

Indicator have the adjust cover on the rear-panel.

Opening the cover,10EA of dip-switch is in this cover,please adjust the zero value

With adjustment key 1 6No of dip-switch closed bewteen 5000 and 15000

Don't use the 7.8No of dip-switch when adjusting a zero point.

10No dip-switch is to adjust the calibration (ON: prohibition,OFF: permittion).

(Example)

Question: At present 27300 and dip-switch all condition "ON".

Answer : If 1No of dip-switch was OFF,also the changing range was 980,

The changing range of Each dip-switch is as follows

Dip-switch	1	2	3	4	5	6
Changed range	980	1960	3920	7840	15680	31360

If 1,2,3,5 dip-switch was OFF,the changed range is $980+1960+3920+15680=22540$.

As the result of,it will come to $27300-22540=4760$ and will result in about 5000.

3-2. SPAN ADJUSTMENT

what is span adjustment.

Span adjustment is to make the display value from "0" to max.weight consistent to
The actual weight

Please do **OFF** NO 10 of dip-switch(Calibration Permission)

How to access the SPAN ADJUSTMENT.

There are 2ways to access the span adjustment

The first way

Turn on the power while pushing **ⓄKey**.then,the display will be "**tEST**"
Then,pushing **ⓄKey** again,it will be displayed with "**St. CAL**"
Also,pushing **SET/CAL** on the below right. it will be displayed with "**d xx**"
("xx" means 01, 02, 05, 10, 20, 50)

예) POWER OFF CONDITIONS

1. While pushing **Ⓞ Key** ----- Display is "**tEST**"
2. Pushin **Ⓞ** key again. ----- Display is "**St. CAL**"
3. Pushing **SET/CAL** key ----- Display is "**d 02**"

The second way

- ① If pushing **SET/CAL** key for 3sec,it will be displayed "St. CAL"
- ② "**St. CAL**" means SETUP & CALIBRATION mode

HOW TO ADJUST SPAN.

S&C MODE have 7 way to adjust span. each step will be advanced with **SET/CAL key**. Also, **CLR** key was used to return the prior conditions.

F.F : **SET/CAL** key

Review : **CLR** key

1Step.

A step to set up a division value and decimal point.

"d" means "Division" and "xx" means a division capable of displaying.

Also this value will be displayed as 01-02-05-10-20-50 by each key.

In case decimal point is "0.0", it will be 2

In case decimal point is "0.00", it will be 3

In case decimal point is "0.000", it will be 4

If decimal not, push 1 key and **SET/CAL key**,

So, it will be go to the next step recording the position of decimal point.

2Step

A step to set up max.weight.

The display will appear "**CAPA**" (Capacity) and discretion number (max. 6 figure)

It can input the maximum weight as the end-user demands instead of discretion number.

How to input is to push **SET/CAL** key after inputting discretion number.

Don't excess (A division ÷ Max.weight) with over **1/20,000**

If excessing over **1/20,000**, it will appear "**Err 01**".

3Step

A step to check the zero conditions of Indicator.

After appearing "**dEAd**", the discretion number (Max. 5 figure) will appear.

If the present number is closed by 5,000, please push **SET/CAL key**.

If a discretion number don't appear and is over 20000,

Please do it as the zero adjustment instruction.

4Step

Indicator will display the capacity at weight column which was set at 2 step after being displayed " S P A n " .

Please input the value of standard weight for span adjustment by numeric key. This value of span standard weight must be equal to full capacity, or over 10% of full capacity.

(In case of less 1/5,000 resolution ,the value of standard weight must be over 10% of full capacity at least.)

(In case of over 1/5,000 resolution ,the value of standard weight must be over 20% of full capacity at least.)

(Notice) If span capacity is set less 10% ,indicator will display error message.

(E r r 0 2 or E r r 0 3)

5Step

Please put the span standard weight on the platform.(the weight is 1000kg at here)

Press SET key after stable of platform.

CAL

(Notice) If indicator is unmatched with load cell capacity or span standard weight,

indicator will display error message (E r r 0 4)

6Step

Indicator will display any constant value of span adjustment.

If the range of this constant value is between 0.5000 -- 3.50000,

All procedure of span adjustment is normal.

And then,press SET key for next procedure.

CAL

If you remember this constant value , you can adjust the span without standard weight by F99 (Function number 99) at set-up mode.

(Please remember this constant value,full capacity and one digit for your further calibration & reference)

7Step

The "END" message is displayed in 6 step,

all span adjustment is end.

Press SET key after put down of span standard weight on the platform.

CAL

The indicator will enter into user's weighing mode.

For Example of SPAN ADJUSTMENT

- * Max.Display Division : 50.00kg
- * Display Setting Interval : 10g
- * When the 10kg of standard balance was prepared.

First Condition	S&C Choice Mode	St. CAL
1 STEP	Pushing SET/CAL Key	d 50
	Ajusting a interval pusing ⓪key	d 01
	Setting a decimal pushing ⓪key	d 0.01
2 STEP	Pushing SET/CAL Key	After displaying CAPA C 80.00
	Pushig a Numeral Key ⓪⓪⓪⓪	C 50.00
3 STEP	Pushing SET/CAL Key	After displaying dEAd d 4879
	If a display value was not between 1000-20000, It should adjust ZERO.	
4 STEP	Pushing SET/CAL Key	After displaying SPAn S 50.00
	Pushig a Numeral Key ⓪⓪⓪⓪	
5 STEP	Pushing SET/CAL Key	Load
	Loading a balance on the weighing part.	
6 STEP	Push SET/CAL after 3sec till The weight will be safty	0.97482
7 STEP	Pushing SET/CAL Key	End
	Push SET/CAL key After unloading a balance	"FlnE" after checking inside ZERO & 7 Segment display
	In the weight display	If it display 0.00 It will be normal

3-3. ERROR MESSAGES & ADJUST

tEst or **FS-XXXX** : If indicator display only " tEst " or FS-XXXX (Model number) without any operation ,first of all you must adjust "dip switch" of back side panel for span and zero value.

ERR--01

Cause : In case resolution (A Interval/Max.display weight) was set over 1/20,000 resolution.

Adjust : Set under 1/20,000 resolution(A Interval/Max.display weight)

ERR--02

Cause : In case Standard Balance weight was more than Max CAPACITY

Adjust : Make Set Standard Balance weight equal or less than Max CAPACITY

ERR--03

Cause : In case Standard Balance weight for span adjust was set less than 5% of Max CAPACITY

Adjust : Set Standard Balance weight for span adjust into less than 5% of Max CAPACITY

ERR--04

Cause : In case the weight was not safty when it account the value of a span constant

Adjust : Adjust a span after removing a cause to be unsafty

ERR--05

Cause : In case the acual weight was more than Standard Balance weight

Or the amplification quantity of Analog circuit inside was more than.

Adjust :

- Please check it if the actual weight was more than Standard Balance weight or not

If it did so,please adjust the standard weight into the value set up.

- If it continue to display ERR--05,please adjust NO 7,8 of Dip-Switch on the rear panel.

For a reference,

NO 1 ~6 of Dip-Switch is to adjust ZERO.

NO 7 ~8 of Dip-Switch is to adjust SPAN

Also because ZERO was changed according to NO 7 ~8 of Dip-Switch,

Please adjust ZERO again as **3-1 ZERO Adjustment**

- The way to use the Dip-Switch.

NO 7	NO 8	Amplification Size	
ON	ON	Small	1time
OFF	ON	Normal	2times
ON	OFF	Big	3times
OFF	OFF	Very Big	4times



- Please adjust SPAN again after adjusting less than the present adjusted value.

If it continue to display ERR--05 in spite of adjusting the Dip-Switch as the above,
Please check it if the cable wire of a Load cell was normal or nor.

ERR--55

Cause : In case a cable wire of a Load cell was connected on reverse.

Adjust : Please check the connection of a Load cell as a reference of **2.3 CHAPTER**

ERR--06

Cause : In case the actual weight was loaded less than standard balance weight
Or was less than Analog Circuit Amplification.

Adjust :

- Please adjust a standard balance weight into the weight set up.

- If continue to display ERR--06, Adjust NO 7,8 of the Dip-Switch on the rear panel.

For a reference,

NO 1 ~6 of Dip-Switch is to adjust ZERO.

NO 7 ~8 of Dip-Switch is to adjust SPAN

Also because ZERO was changed according to NO 7 ~8 of Dip-Switch,

Please adjust ZERO again as **3-1 ZERO Adjustment**

- The way to use the Dip-Switch.

- Please adjust SPAN again after adjusting less than the present adjusted value.

NO 7	NO 8	Amplification Size	
ON	ON	Small	1time
OFF	ON	Normal	2times
ON	OFF	Big	3times
OFF	OFF	Very Big	4times



If it continue to display ERR--06 in spite of adjusting the Dip-Switch as the above,
Please check it if the cable wire of a Load cell was normal or nor.

ERR--07

Cause : In case it was deviated from a range of value which can be set by SET UP,

Adjust : Please input the contents of SET UP again.

ERR--10

Cause : In case the record device of Memory or Hardware was not normal

Adjust : It can be worked by a voluntary key, but it was temporary way.

So, please try to send this Indicator to the head office for A/S.

" UL " (UNDER LOAD)

Cause : In case the connection of a Load cell was not normal or a Load cell was broken.

Adjust : Please refer to the part related with a Load cell or **CHAPTER 3 ZERO ADJUSTMENT**.

" OL " (OVER LOAD)

Cause : In case the connection of a Load cell was not normal or a Load cell was broken.

Adjust : Please refer to the part related with a Load cell or Remove an excess weight.

CHAPTER 4. SET-UP

4-1. PREFACE

" SET-UP " is to choose each proper functions for matching the indicator with the appliances of field.

How to enter into set-up mode

This set-up mode is required for proper weighing operation when Indicator connects With other appliance. It can enter into sep-up mode by the below two steps.

The first Step

Depress key "**Ⓞkey**" first and power on at the same time.

At that time, "**tEst**" word will be displayed on indicator.

Depress key "**Ⓞkey**" again, and indicator will display as following :

S t, C A L. ; S & C Mode

At this time,press CLR key.

Indicator will display to " F01-xx " from above test message.

* For example

The power was OFF

1. Power "ON" while pushing **Ⓞkey** ----- "**tEst**"
2. Pushing **Ⓞkey** again ----- "**St. CAL**"
3. Push **CLR key** ----- "**F01 - xx**"

The second Step

If you depress key " SET/CAL" for 3 seconds at the normal weighing mode,

Indicator will also display "**St. CAL**" as the above.

4-2.SET-UP

If it press **CLR** key at S&C Mode,Indicator will display "**F01-xx**"

The F of "**F01-xx**" means Function and 01 means Function number

And the last 2figure "**-xx**" means each functional setting number

* For example

Pushing CLR key in "**St. CAL**" mode

F01-01

Function number will be increased to the next Function whenever it pushes .

If you proceed to next function,press CLR key or,

If you want to see your desirous any function number,

Press "CLR" key after input any function number by numeric key.

Indicator will display function number directly from present function number.

4-3. F-FUNCTION SUMMARY LIST

(EXAMPLE)

* Present display : F01-01

Press CLR key ----> "F02-00" display ----> Press CLR key.

----> "F03-01" display ----> Continuously press CLR key ---->

"F04-XX" ----> "F05-XX" ----> "F06-XX" ---->

Press CLR key in streams, the next function number will be displayed.

* Present display : F01-01

If you want to see function number 12,

Press numeric key "1" and "2" ----> Press CLR key ----> "F12-XX" display

) If you want to change each functional setting number newly,

Press SET key after input the functional setting number by numeric key.

CAL

(EXAMPLE)

If "F01-01" is changed to "F01-03",

Press 3 key ----> F01-03 display ----> Press SET key.

K.T.

CAL

A new function number will be memorized.

(Remarks) When you want to change " S & C MODE " from Set-up mode,
Please press key " 0 " + " CLR " consecutively.

ERR--07

Cause : In case it was deviated from a range of value which can be set by SET UP,

Adjust : Please input the contents of SET UP again.

F-NO	FUNCTION	CONTENTS
F-00 GROUP-SETTING A BASIC WEIGHIG		
F 00	S & C MODE Convert	SETUP & CALIBRATION
F 01	weight unit choice	kg, ton, lb
F 02	weight BACK-UP	NORMAL, BACK-UP
F 03	Set ZERO tracking Range	0, 0.5, 1, 2
F 04	Set Safty Motion Band	0.5, 1, 2, 4, 8
F 05	Set AUTO ZERO Range	0-99 (Auto Zero Range)
F 06	Digital Filter	0-9 (anomalous decrease)
F 07	Set ZERO Range	Max.weight 2, 10, 50, 90%
F 08	Set Delay time of Safty judgement	0-99 (1count = 0.1sec)
F 09	Available ZERO Range setting	1000-20000, No limit
F-10 GROUP-SETTING A BASIC DEVICE		
F 10	Selecting a Key Lock	Prohibition & Permit for KEY
F 11	ZERO,TARE,OPERATE MODE	Satty,Unsafey
F 12	TARE weight INPUT MODE	Set Numeral,Actual,Auto TARE
F 13	EMPTY Signal MODE	Output Choice when it is ZERO or Empty
F 14	SET EMPTY Range Set	Set Empty Range Weight
F 15	SET EMPTY Standard Set	Display weight,basic ZERO,TARE ZERO
F 16	External INPUT MODE	Input terminal function
F 18	DELETE Totalization information	Delete in Manul/Auto for totalization
F 19	Manual,Auto Choice	Delete in Manul/Auto when Indicator is ON
F-20 GROUP-SETTING CONTROL SYSTEM		
F 21	User key definition	No definition or Set
F 22	User key definition	No definition or Set
F 23	User key definition	No definition or Set
F 24	Set AUTO Function	Choice for Safty,Output,Hold
F 25	Set HOLD Function	Hold,Max Hold,Average Hold
F 26	Nomination CODE Number	No change,increase,decrease in working ltime
F-30 GROUP-SETTING Serial Interface Specification		
F 30	BRUD RATE	300, 600, 38.4 kbps
F 31	Set Parity Bit	EVEN, ODD, NO PARITY
F 32	Set Transmit MODE	Continue,Satty,Totalization,Command.
F 33	Set Format Transmit DATA	weight, weight+time, CAS tranmit format
F 34	Insert Transmit DATA (STX)	No, Insert
F 35	Control Interface wire / RS,CS	No use(RS422/485), USE
F-50 GROUP-SETTING BCD Output Specification		
F 50	Weight choice for output	Display,Gross,Net weight
F 51	BCD OUT Parity	Positive / Negative OUT
F-60 GROUP-SETTING Analog Out Specification		
F 60	Weight choice for output	Display,Gross,Net weight
F 61	Standard weight choice of Analog Out	Max,display weight,Standard weight

CHAPTER 5. SET-UP ILLUSTRATION

5-1. BASIC FUNCTION FOR WEIGHING

F00-	S&C MODE 전환	
-------------	------------------------	--

SET UNIT WEIGHT		
F01-	⓪	kg
	1	ton

WEIGHT BACK-UP		
F02-	⓪	NORMAL
	1	BACK-UP
<p>NORMAL Condition is unavailable to back up the weight on the weighing part In No power or OFF So, please turn on the power after removing it BACK-UP means that the weight weighing in OFF keeps the weight When the power turns on (KEY) Set BACK-UP MODE after adjusting the weight on NORMAL condition</p>		

SET ZERO TRACKING RANGE		
F03-	0	No ZERO TRACKING
	⓪	0.5DIGIT / 0.25sec
	2	1DIGIT / 0.25sec
	3	2DIGIT / 0.25sec
<p>What is ZERO Tracking ? If A weight continue to change with a small value, It displays the weight in spite of No product on the weighing part. It is to compensate such a value.</p>		

SET SAFTY MOTION BAND			
F04-	0	0.5 Devision	<p>Motion Band ? It means compensating a termpoary tramble If the weight change was less than the present set value for the time set by F-08, it will be a safty jusding.</p>
	⓪	1 Devision	
	2	2 Devision	
	3	4 Devision	
	4	8 Devision	
<p>When the weight change`s difference was in the range set for a time, This function will make it safty. If the factory environment have much vibration, please enlarge the motion band. Also, if it was lower, please make it smaller.</p>			

SET AUTO ZERO RANGE		
F05-	0	This is to make the weight of last two digits as zero automatically. * First Set 00
	99	
<p>(Example) If the indicator is set to 15kg * 5g and f05-30 , The range of auto zero will be to 1--30g. At this time, F05 function is available up to 10 % of full capacity.</p>		

DIGITAL FILTER			
F06-	0	LESS	* Requesting a high speed response (0, 1, 2) * A general Weighing (3, 4 ,5,6) * A greater vibrating (7,8,9)
	9	MORE	
<p>If you use the indicator with conveyer belt system or any other vibrating appliance, this f06 function will be applied for filtering or absorbing the vibrating or oscillating weighing value.</p>			

SET ZERO RANGE		
F07-	⓪	Under 2% of Maxium available weight
	1	Under 10% of Maxium available weight
	2	Under 50% of Maxium available weight
	3	Under 90% of Maxium available weight
<p>Setting ZERO can be set in the range by ZERO Key or External ZERO Input Notice : Set Zero Ragne(50%),Load cell Capacity(100kg),Set Zero(50kg) Then,if the acutual weight is 100kg,it means weighing total 150kg On a load cell.So,The load cell may be broken. Please refer to Max.capacity of a load cell.</p>		

SET DELAY TIME OF SAFTY JUDEGEMENT		
F08-	0	A weight is a deviation range set by F-04 and after time set,it will be a safty display and auto mode. * First Setting : 10 (1 sec) * 0.1sec Delay/per 1count
	99	

AVAILABLE ZERO RANGE SETTING		
F09-	⓪	Zero value of 1000 ~ 20,000 while working.
	1	No availabel to Zero value while working
Unavailable to set by F02-01(BACK-UP)		

5-2 . BASIC FUNCTION FOR DEVICES

SELECTING A KEY LOCK.		
F10-	①	Available to use all keys
	1	Unavailable to use G/T,S/T,HOLD,AUTO,PRINT,GROSS KEYS
	2	Unavailable to use ALL KEYS except of ZERO POINT KEY.
This function was designed to prevent from mis-operating by general user.		
ZERO & TARE KEY OPERATING MODE		
F11-	①	Zero & Tare KEY will be operated when a weight was steady.
	1	Zero & Tare KEY will be operated though a weight was not steady.
TARE WEIGHT INPUT MODE		
F12-	0	Setting TARE Value after inputting SET/CAL
	①	Setting TARE Value with inputting only by TARE KEY In the situation of putting a weight,tare On a weighing plate.
	2	<p>Auto Tare Setting if a weight was steady on EMPTY weight area. Under tare set-up situation, If Display Weight was steady under Empty Area, It will be AUTO TARE RE-SETTING.</p> <p>(It is comfortable in case that TARE weight remove automatically before working and weighs it after working)</p>
	3	<p>If Gross Weight was steady under Empty area, It will be AUTO TARE REMOVING.</p> <p>(It is comfortable in case that the filling works after loading TARE on the weighing part.</p>
* In case selecting NO 2,3,The TRAE Key will be worked to NO 1		

EMPTY SIGNAL MODE		
F13-	0	If a weight is ZERO("0"),Empty signal will be showed.
	①	Empty Signal will be showed on a weight ("0" or "under 0")
	2	Empty Signal will be showed on a absolute value Of Empty range
	3	It will be showed on "+range","-range".
* The occurrence of Empty will display ZERO LAMP		

SET EMPTY RANGE		
F14-	EMPTY RANGE	Through Setting Empty Range,AUTO Funtion (TARE,G/T,S/T,HOLD) will be used pratically. * FIRST SETTING 000010

SET EMPTY STANDARD		
F15-	①	Standard for a weight displayed .
	1	Standard for Basic Zero value .
	2	Standard for Zero value by TARE setting.

EXTERNAL INPUT MODE					
F16-		INPUT 1	INPUT 2	INPUT 3	INPUT 4
	①	ZERO	TARE	N/W	G/W
	1	ZERO	TARE	PRINT	G/W
	2	ZERO	TARE	HOLD/Remove	HOLD
	3	ZERO	PRINT	SUB TOTAL	TOTAL
	4	ZERO	TARE	SUB TOTAL	TOTAL
* Input in connecting COM terminal and Input Terminal. The time to input is over 0.05 sec * Convert in inputting N/W.					

Delete Totalization Information		
F18-	①	CLR + SUB TOTAL , Deleting in inputting CLR + TOTAL .
	1	Auto deleting in printing Sub-Total,TOTAL

MANUL,AUTO CHOICE		
F19-	⓪	Passivity MODE on power source " ON "
	1	AUTO MODE on power source " ON "
* In case using AUTO MODE,Please set NO 1		

F1 KEY FUNCTION SETTING BY USER		
F21-	⓪	No AVAILABLE
	1	DATE
	2	TIME
	3	DATE & SET.
	4	TIME & SET.
	5	SUB TOTAL WORK NUMBER
	6	GROSS TOTAL WORK NUMBER
	7	SUB TOTAL .
	8	GROSS TOTAL
	9	P.N WORK START DATE
	10	P.N WORK FINISH DATE
	11	P.N WORK START TIME
	12	P.N WORK FINISH TIME.

F2 KEY FUNCTION SETTING BY USER.		
F22-	The above F1 FUNCTION SETTING is the same	
	⓪	No available

F3 KEY FUNCTION SETTING BY USER		
F23-	The above F1 FUNCTION SETTING is the same	
	⓪	No available

SET AUTO FUNCTION		
F24-	⓪	Auto S/T,G/T in case of HOLD MODE
	1	Auto HOLD Function (In case F25-00,01 it is unavailable)
	2	Auto HOLD Function & Empty HOLD Auto Remove
	3	Auto S/T,G/T on a steady Lamp
	4	Auto S/T,G/T when a steady weight was in Empty area.
<p>Additional Reference</p> <p>0 : The function to totalize when setting the HOLD on auto display [It can use it in totalizing and fixing it at the present weight According to USER.</p> <p>1 : The function to operate HOLD command and display automatically To satisfy F25 without separate HOLD command. [When USER use always HOLD INPUT, This function will be effective.</p> <p>2 : The same as the above, when it was EMPTY range, The HOLD command removes and turn out. [The same as the above function, But The HOLD remove automatically).</p> <p>3 : It auto-totalize displaying a steady while weighing the weight. [Available to record the weight and to print it.</p> <p>4 : After displaying the last steady Lamp while weighing it, When the Empty range will be after removing the products, Then the last steady Lam`s weight will be totalized. [The function to totalize it without printer KEY.)</p>		

SET HOLD FUNCTION		
F25-	⓪	Holding the present weight as setting HOLD KEY.
	1	Holding a balanced weight for a steady judgment delay time
	2	When a steady lamp was displayed
	3	When maximum weight was displayed(1 time)
	4	Holding a weight when Maximum weight was displayed And when Maximum weight was renew.

NOMINATION CODE NUMBER		
F26-	⓪	FIXING
	1	1 Increase after weighing 1time
	2	1 Decrease after weighing 1time ("0" is No Decrease)

SET DEVICE IDENTIFICATION NO		
F90-	00	Unavailable for ID NO in case of '00' setting. Available for ID NO in case of INPUTTING ID NO * First Setting 00
	99	

DATE MODIFICATION MODE	
F95-	<p>Example)</p> <p>Display "F01-00"</p> <p>⑨ key ⑤ key CLR key</p> <p>In case of 97year 09month 30day 2001year02month14day</p> <p>① key ① key ① key ② key ① key ④ key</p> <p>SET/CAL</p>
* DATA & TIME was subjected to the OPTION setting.	

TIME MODIFICATION MODE	
F96-	<p>Example)</p> <p>Display "F01-00"</p> <p>⑨ key ⑥ key CLR key</p> <p>17hour 25min 30sec 21hour 55min 56sec</p> <p>② key ① key ⑤ key ⑤ key ⑤ key</p> <p>⑥ key SET/CAL key</p>
* DATA & TIME was subjected to the OPTION setting.	

CHECK A/S COUNT OF BASIC ZERO	
F98-	* This key was used to check a load cell Error.

5-3 SERIAL INTERFACE (RS-232C,CURRENT LOOP,RS-422/485)

SET BRUD RATE																																	
F30-	0	300 bps	⑤	9600 bps																													
	1	600 bps	6	14.4k bps																													
	2	1200 bps	7	19.2k bps																													
	3	2400 bps	8	28.8k bps																													
	4	4800 bps	9	38.4k bps																													
SET PARITY BIT																																	
F31-	①	EVEN																															
	1	ODD																															
	2	NO PARITY																															
SET TRANSMIT MODE																																	
F32-	①	Stream (Output in streams)																															
	1	A continuous data output when a weight was steady																															
	2	A continuous data output when a real product`s weight Was steady																															
	3	Data output when print,hold key push																															
	4	COMMAND MODE TRANSMISSION																															
	5	Serial Printer MODE ONLY																															
SET FORMAT TRANSMIT DATA																																	
F33-	①	<table border="1" style="width: 100%; text-align: center;"> <tr> <td>S</td><td>T</td><td>.</td><td>N</td><td>T</td><td>.</td><td></td><td></td><td></td><td>k</td><td>g</td><td>(CR)</td><td>(LF)</td> </tr> <tr> <td>□</td><td>□</td><td>□</td><td>□</td><td>□</td><td>□</td><td>□</td><td>□</td><td>□</td><td>□</td><td>□</td><td>□</td><td>□</td> </tr> </table> Header1 Header2 weight(8) unit			S	T	.	N	T	.				k	g	(CR)	(LF)	□	□	□	□	□	□	□	□	□	□	□	□	□			
	S	T	.	N	T	.				k	g	(CR)	(LF)																				
	□	□	□	□	□	□	□	□	□	□	□	□	□																				
1	<table border="1" style="width: 100%; text-align: center;"> <tr> <td>S</td><td>T</td><td>.</td><td>N</td><td>T</td><td>.</td><td></td><td></td><td></td><td>k</td><td>g</td><td>.</td><td></td><td>(CR)</td><td>(LF)</td> </tr> <tr> <td>□</td><td>□</td><td>□</td><td>□</td><td>□</td><td>□</td><td>□</td><td>□</td><td>□</td><td>□</td><td>□</td><td>□</td><td>□</td><td>□</td><td>□</td> </tr> </table> Header1 Header2 weight8) unit time(6)			S	T	.	N	T	.				k	g	.		(CR)	(LF)	□	□	□	□	□	□	□	□	□	□	□	□	□	□	□
S	T	.	N	T	.				k	g	.		(CR)	(LF)																			
□	□	□	□	□	□	□	□	□	□	□	□	□	□	□																			
2	<table border="1" style="width: 100%; text-align: center;"> <tr> <td>S</td><td>T</td><td>.</td><td>N</td><td>T</td><td>.</td><td></td><td></td><td></td><td></td><td></td><td></td><td></td><td>k</td><td>g</td><td>(CR)</td><td>(LF)</td> </tr> </table>			S	T	.	N	T	.								k	g	(CR)	(LF)													
S	T	.	N	T	.								k	g	(CR)	(LF)																	
* ID NO will be displayed automatically when setting of ID NO of F-90																																	
* No availabel in case fo F33 - 02																																	
INSERT TRANSMIT DATA(STX)																																	
F34-	①	NO STX																															
	1	Transmition of STX(ASCII=02)																															
CONTROL INTERFACE WIRE/ RS422 (485)																																	
F35-	①	NO USE for CS, RS / in case of RS422,485																															
	1	USE FOR CS, RS																															

Receive Program example (Personal Computer)

In case of setting of F30-00, F31-00, F32-00, F33-00, F34-00

Basic Program

```
10 OPEN "COM1: 300, E, 7, 1, DS, CS" AS # 1
20 INPUT #1, A$, B$, C$
30 PRINT A$, B$, C$
40 GOTO 20
```

5-3-2. OP-02 CURRENT LOOP

Current Loop System is more safety for electric Noise rather than RS-232C.

But, please use the Interface speed with 4800 bps.

And please connect AC Power Cable with other electric wire seperately.

Also specially please use the CABLE with Shield Coax Cable surely.

For reference, a recommand distance is in 100 M and a wire registance must be 500

SINGAL FORMAT

0	20mA
1	0mA

Same as 5-1 RS-232 option

DATA FORMAT

Same as 5-1 RS-232 option

25P D-Type Female Connector

- * Please use the connector like RS-232C Interface
- * Transmission terminal was NO Polarity.
- * Reception terminal was supplied with 12V for a current supply

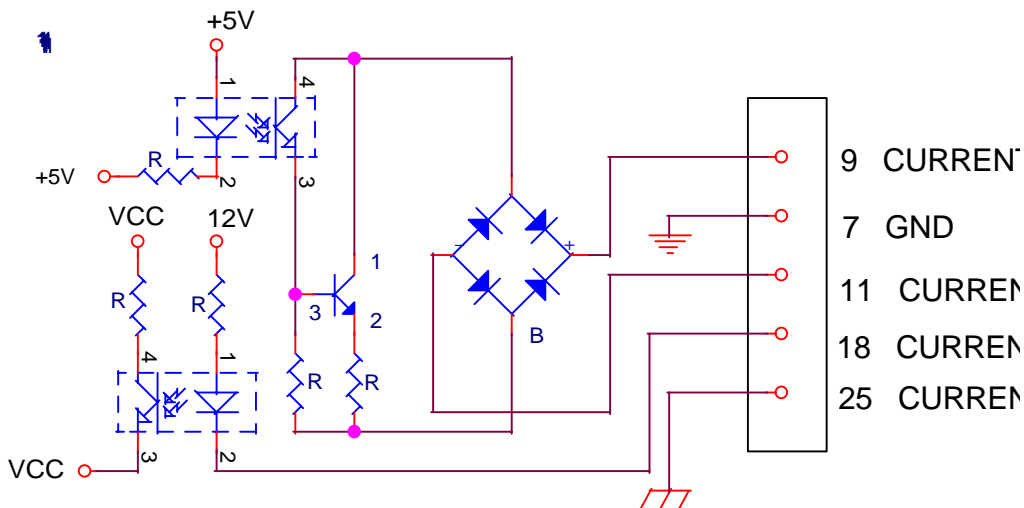

COMMAND MODE FORMAT

COMMAND	FUNCTION	RESPONSE	
		COMMAND MODE (F32-04)	Transfer Mode
R CR LF	demand current weight	Standard DATA FORMAT	No receive
T CR LF	Same as [TARE] Key	ACK CR LF	NO
KT weight(6) CR LF	Same as [TARE] Key	ACK CR LF	NO
G CR LF	Change to 'Gross Weight	ACK CR LF	NO
N CR LF	Change to 'Net Weight	ACK CR LF	NO
Z CR LF	Same as [ZERO] Key	ACK CR LF	NO
P CR LF	Same as [PRINT] Key	ACK CR LF	NO
A CR LF	Same as [Sub-total] Key	ACK CR LF	NO
M CR LF	Remove Auto setting	ACK CR LF	NO
ST CR LF	Same as [Sub-total] Key	ACK CR LF	NO
GT CR LF	Same as [TOTAL] Key	ACK CR LF	NO
STC CR LF	Deleting Sub-total	ACK CR LF	NO
GTC CR LF	Deleting TOTAL	ACK CR LF	NO
HON CR LF	Setting HOLD	ACK CR LF	NO
HOF CR LF	Remove HOLD	ACK CR LF	NO
PN (2) CR LF	Change PART	ACK CR LF	NO
CD (6) CR LF	Setting CODE 6 figure	ACK CR LF	NO
DT YYMMDD CR LF	Setting DATE	ACK CR LF	NO
TI HHMMSS CR LF	Setting TIME	ACK CR LF	NO
RDT CR LF	Demend DATE	YY MM DD CR LF	No receive
RTI CR LF	Demend TIME	HH MM SS CR LF	No receive
RPN CR LF	Demend PART	PART(2) CR LF	No receive
RCD CR LF	Demend CODE NO	CODE (6) CR LF	No receive
RST CR LF	Demend Sub-total data	PART(2), FREQUENCY(6),WEIGHT(11) CR LF	No receive
RGT CR LF	Demend Total data	FREQUENCY(8) , WEITHT (13) CR LF	No receive
REN CR LF	Demend The last Weight	WEIGHT(7) CR LF	No receive

* F90- (01-99) Setting : It should add to 2figure of device ID no.

* F34- 01 : The start of Interface will be STX(ASCII=02).

5-4. Additional Set-up Function

5-4-1 OP - 03 BCD OUTPUT

Parallel BCD OUT is a device to output after make the displayed weight into BCD CODE. Also, this device is to control, display, record as connected with PLC (Programmed Logic Control).

* A recommend distance is in 10 M

* BCD code makes a denary into 4 figure of a binary number

(Example)

In case of BCD 1987, it display **0001 1001 1000 0111**

BCD OUTPUT Weight Selecting		
F50-	⓪	Displayed Weight Value
	1	GROSS Weight
	2	NET Weight

BCD OUTPUT POLARITY		
F51-	⓪	Positive Logic
	1	Negative Logic

Connected Pin drawing

PIN NO	SIGNAL	50 PIN	PIN NO	SIGNAL
	GROUND (GND)			
1	1×10^0		26	Hi : Net LOW : Gross
2	2×10^0		27	
3	4×10^0		28	
4	8×10^0		29	
5	1×10^1		30	
6	2×10^1		31	
7	4×10^1		32	
8	8×10^1		33	
9	1×10^2		34	
10	2×10^2		35	
11	4×10^2		36	
12	8×10^2		37	EX. Vcc
13	1×10^3		38	
14	2×10^3		39	EX. Vcc
15	4×10^3		40	
16	8×10^3		41	
17	1×10^4		42	Hi : Positive Polarity
18	2×10^4		43	Decimal Point 10^1
19	4×10^4		44	" 10^2
20	8×10^4		45	" 10^3
21	1×10^5		46	
22	2×10^5		47	OVER LOAD
23	4×10^5		48	
24	8×10^5		49	BUSY
25	1×10^6		50	HOLD (INPUT)

- ▶ CONNECTOR: CHAMP 57-40500(Ampheonol) (Female)
- ▶ TTL OPEN-COLLECTOR OUTPUT
- ▶ HOLD INPUT should be connected with OPEN COLLECTOR TYPE or Switch Earth.
- ▶ And OUTPUT DATA will hold while HOLD INPUT

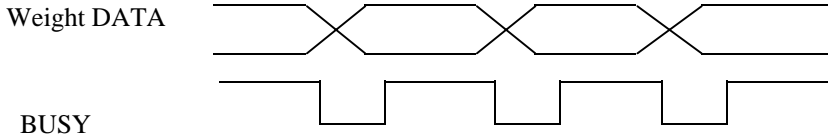

- ▶ Signal Logic
 - ① Weight BCD DATA OUTPUT Positive)/Negative .
 - ② POLARITY OUTPUT “ - ” = L
 - ③ OVER “ OVER ” = L
 - ④ BUSY “ BUSY ” = L
 - ⑤ BCD HOLD “ HOLD ” = L (INPUT)

BCD OUTPUT CIRCUIT

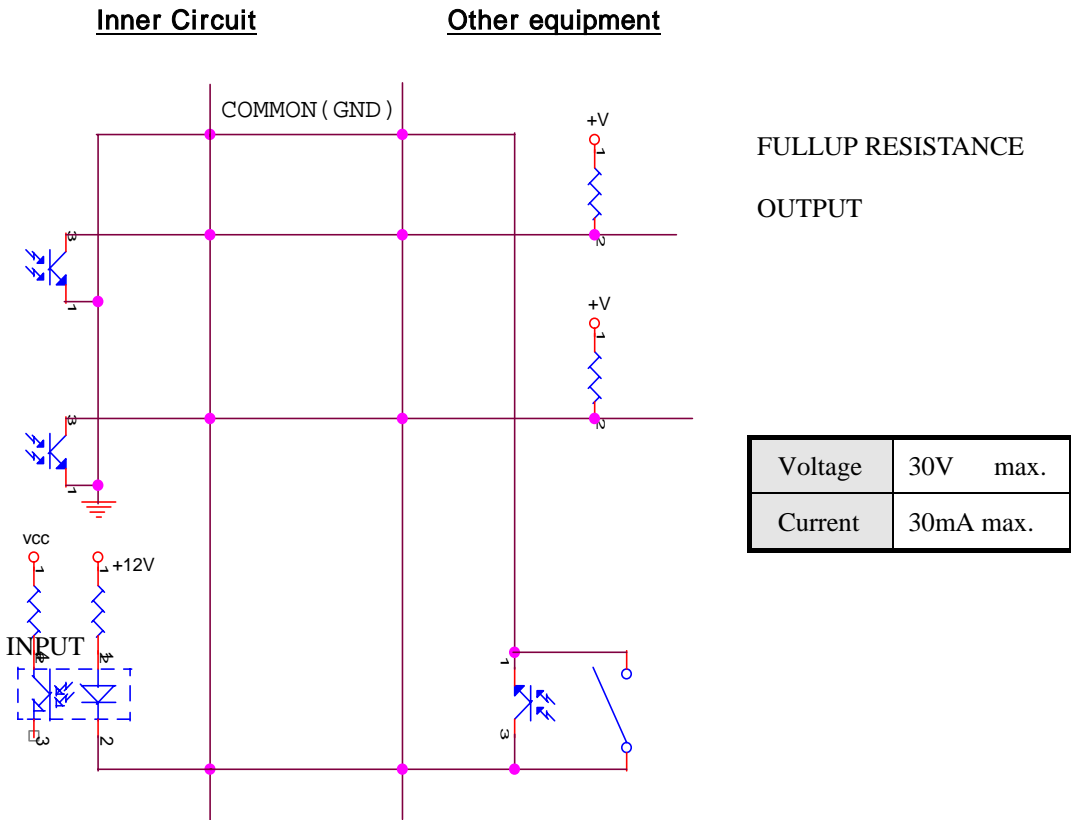

- ▶ OUTPUT CIRCUIT IS OPEN COLLECTOR TYPE
- ▶ If output demand TTL LEVEL ,insert full up - resistance to a board of BCD OPTION
- ▶ When inserting a fullup resistance ,please change 5v 30V in **37,39 NO** Resistance and Voltage .
 - 5V = 1 k , 10V = 2 k , 15V = 2.7k , 24V = 5 k**

5-4-2 OP-04 RS-422 / 485 Serial Interface

* RS-422/485 is to transmit the signal by the Voltage Variation

So, It is more safety than other for a electric noise.

* RS- 485 should be connected as follows.

RXD(+) + TXD(+), RXD(-) + TXD(-)

***Please Specially connect them Separately disconnecting AC Power Cable or Other Wire**

* Also Cable should be surely connected with Shield Twist Cable.

* Recommended Distance is in **1.2 km** .

* Terminations Resistance of 300 should be connected on the end sides of the wire Both end side of a wire

(1) Signal Format

① TYPE : RS-422/485

② FORMAT : Baud-Rate : 300 38.4k . Selection
 Data Bit : 7 or 8 (NO Parity)
 Stop : 1
 Parity Bit : Even, Odd, NO Parity Selection
 Code : ASCII

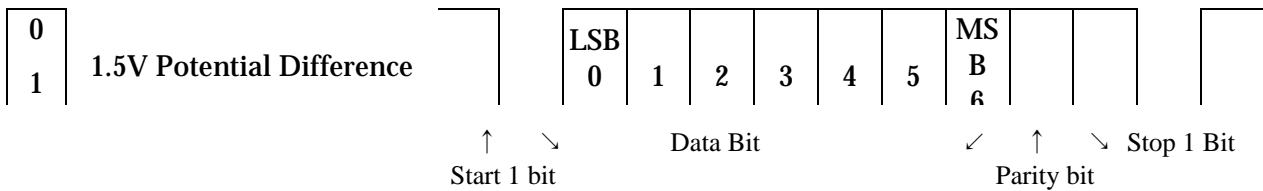

(2) Data Format

● It's the Same with RS - 232C

(3) RS-422 / 485 Circuit (9P D-Type Female Connector)

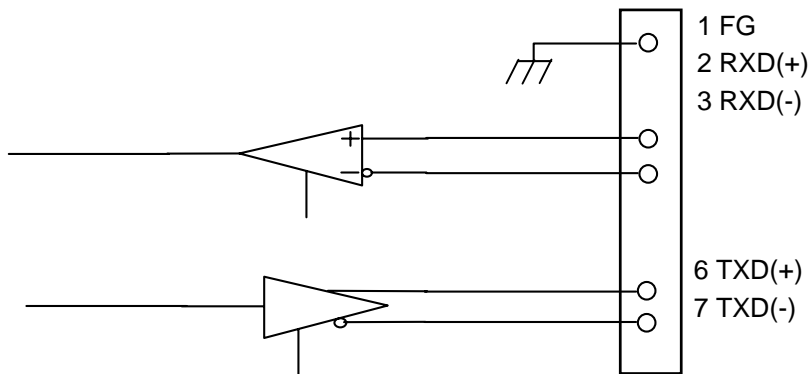

5-4-3 OPTION-05/06 ANALOG OUT

- * This option is a device to output and convert the weight value to External device(Recorder P.L.C Center control so) controlled by Analog Signal.
- * The voltage output occurs proportionally the voltage according to the size of weight in 0V ~10V.
- * The current output occurs proportionally the current according to the size of weight in 4mA~20mA
- * The precision of Analog output is Max.1/3000
So,Unavailable to use it in case of high precision over 1/3000

Analog Out Weight Selecting		
F60-	⓪	displayed Weight value
	1	GROSS Weight
	2	NET Weight
Gross or Net Weight can be different with weight value displayed		

Analog Out standard Selecting		
F61-	⓪	MAx.Weight Standard
	1	Standard value setup by F-63

Analog Out POLARITY		
F62-	⓪	Positive out : 4mA, 0V while weight is 0
	1	Negative out : 20mA, 5V, 10V while weight is 0

Analog Out Standard Weight Selecting.	
F63-	Analog max out value when weight setup. * first Setting 000000

5-4-3V OP-05 voltage (0 10V) Analog out

- * The voltage output occurs proportionally the voltage according to the size of a weight
In 0V ~10V.
- * The type of voltage output can be changed according to SET UP F60

SPECIFICATION

output Voltage	0 10V DC out
Precision	Max 1/3000
Min Impedence	Over 1 k

9P D-TYPE Female & Voltage out circuit

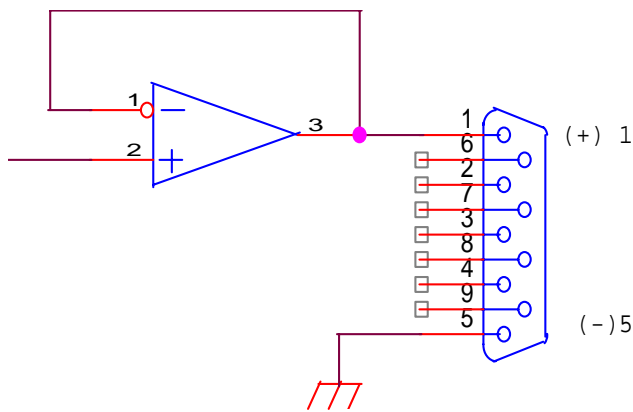

NOTICE

As NO 5 Terminal is not GND, Please don't connect the device such as GND line or BODY GND

Adjustment

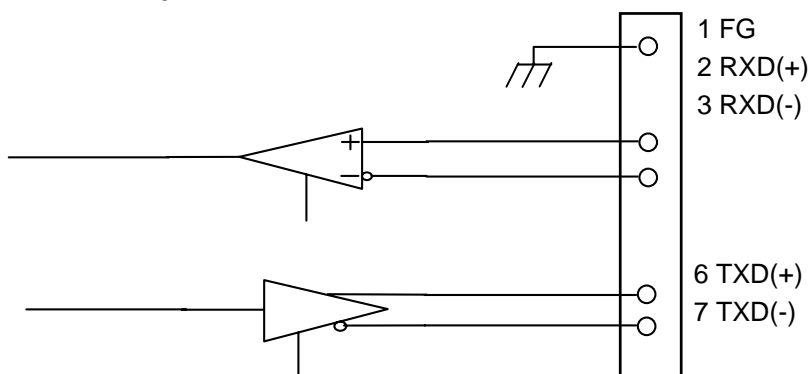

How to calibrate for output rate bewteen 0v and 10v.

- * The voltage out is to 0V when the weight is displayed 0 kg in indicator.
- * The voltage out is to 10V when the weight is displayed max.capacity in indicator.
- * If analog output is not correct,
You can make a fine adjustment with VR1(Zero adjustment) and VR2(Span adjustment)
on analog pc board by multi meter.(Recommended accuracy : 1/3,000)

5-4-3I OP -06 Electric current (4 -20mA) Analog Out

- * The voltage output occurs proportionally the voltage according to the size of a weight
In 4mA ~20mA.
- * The type of voltage output can be changed according to SET UP F60

Specification

output Voltage	4 20 mA DC Current out
Precision	Max 1/3000
Min Impedence	Under 500

9P D-TYPE Female & Current out circuit

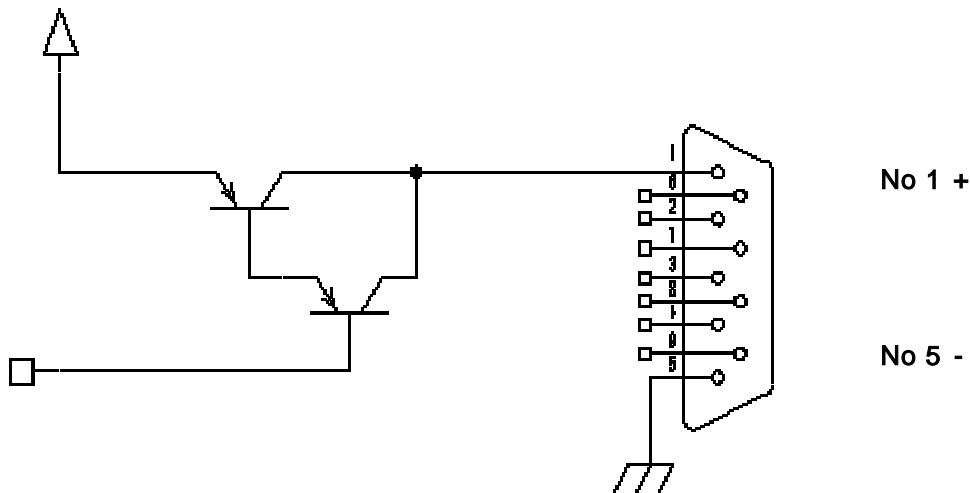

Adjustment

- * The resistor must be used with enough power consumption.
If you used 500 ohm resistor,
 $W = i^2R = (0.02)^2 \times 500 = 0.2 \text{ Watt}$
So, the rate of resistor must be used over than 1/2 watt by 0.2 watt power consumption.
- * **Absolutly do not connect above Lo(-) line to GND line, body GND
Or any similar devices. Because it is -12V, not ground (0V).**

How to calibrate for output rate bewteen 4mA and 20mA.

The current out is to 4 mA when the weight is displayed 0 kg in indicator.
The current out is to 20 mA when the weight is displayed max.capacity in indicator.
If analog output is not correct,
You can make a fine adjustment with VR1(zero adjustment) and VR2(span adjustment)
On analog pc board by multi meter.

5-4-4. OP-07 PRINTER

- * This printer Interface have Centronics Parallel and Serial system.
- * SERIAL is from 1 to 999999
- * CODE figure is 6(six) and set according each PART.
- * SUB TOTAL can be momoried till 10figures.
- * GRD TOTAL can be momoried till 12figures.
- * The data can be kept in spite of stoppage of the power

PRINTER SELECTING		
F71-	⓪	PRITNT SHEET 0
	1	PRTINT SHEET 1

PRINT SHEET 0		
=====		
DATE :	1999-01-01	
TIME :	12:35:07	
CODE :	123456	
SERIAL	PART	WEIGHT
1	1	1.000 kg
2	1	1.100 kg
3	1	1.200 kg
4	1	0.900 kg
5	1	1.000 kg
=====		
SUB-TOTAL		
START :	1998-12-30 8:12	
END :	1999-01-01 14:26	
PART :	01	
CODE :	123456	
COUNT =	5	
WEIGHT =	5.200 kg	

PRINT SHEET 1		
=====		
DATE :	1999-01-01	
TIME :	12:35:07	
CODE :	123456	
SERIAL	PART	WEIGHT
1	1	1.000 kg
=====		
DATE :	1999-01-01	
TIME :	12:35:07	
CODE :	123456	
SERIAL	PART	WEIGHT
2	1	1.000 kg
=====		
SUB-TOTAL		
START :	1998-12-30 8:12	
END :	1999-01-01 14:26	
PART :	01	
CODE :	123456	
COUNT =	2	
WEIGHT =	2.000 kg	

PRINTER PAPER QUANTITY WHEN FINISHING		
F72	0 ~ 99	1 LINE PRINT OUT PER 1COUNT(LINE FEED) * <u>FIRST SET-UP 00</u>
SUB TOTAL PRINTER MODE		
F73	0	SUB TOTAL PRINT SHEET 0
	1	SUB TOTAL PRINT SHERT 1

Sub-total PRINT SHEET 1
=====
SUB-TOTAL
START : 2000-03-28 12:34
END : 2000-03-29 9:50
PART : 1
CODE : 123456
COUNT : 10
MIN : 9.998 kg
MAX : 10.002 kg
AVG : 10.000 kg
=====

Sub-total PRINT SHEET 0
=====
SUB-TOTAL
START : 2000-03-28 12:34
END : 2000-03-29 9:50
PART : 1
CODE : 123456
COUNT : 10
WEIGHT : 100.000 kg
=====

25P D-Type Female Connector

PIN NO.	Contents	PIN NO.	Contents
1	STROBE	14	N.C
2	D0	15	N.C
3	D1	16	N.C
4	D2	17	N.C
5	D3	18	GND
6	D4	19	N.C
7	D5	20	N.C
8	D6	21	N.C
9	D7	22	N.C
10	ACK	23	N.C
11	BUSY	24	N.C
12	N.C	25	N.C
13	N.C		

5-4-5. OP-10 BCD INPUT.

Parallel BCD input is used to change the PART to the external device.
 This device make it effective to weigh a various works changing the PART with a connection of Computer,PLC,Digital Switch.

The inside circuit of Input & Output circuit use a photo-coupler and was isolated from the external

- * Reccommand distance is under 10 M
- * BCD code makes a denary into 4figure of a binary number
- * In case PART 19 displayed with BCE CODE such as 0001 10001
0 = OFF, 1 = ON

15P D-Type Female Connector

When a additional input needs,
 This additional input will be used except of the external 4EA.

BCD INPUT CIRCUIT

PIN NO	SIGNAL
1	1×10^0
2	2×10^0
3	4×10^0
4	8×10^0
5	1×10^1
6	2×10^1
7	4×10^1
8	8×10^1

PIN NO	SIGNAL
9	EARTH (GND)
10	
11	AID INPUT 1
12	AID INPUT 2
13	AID INPUT 3
14	AID INPUT 4
15	EARTH (GND)

