

FS-2000A

Digital Weighing Indicator

INSTRUCTION MANUAL



INTER KOREA CORP

#149, DAEHEUNG-DONG, MAPO-GU, SEOUL, KOREA

TEL : 82 2 3273 3166~8, FAX : 82 2 3273 3169

Http : www.fineweigher.co.kr

Overseas Office Director : Michael Park

CHAPTER 1. PREFACE

1-1. INTRODUCE

Thank you very much for your purchasing FINE Digital Weighing Indicator of **FS-2000A**
This Instruction Manual will lead you to use **FS-2000A** with top reliability,
High speed,high accuracy.

FS-2000A is Digital Weighing Indicator amplifying the analog output from a load
Cell,converting the analog signal to digital data and then displaying this data
As a weight reading and is designed for flawless performance in your demanding
Application of input-weighing,output-weighing,accumulating-weighing, 3step control.
Also, an additional option will make Modern Industry demand equipment that both versatile
And available to easily connect to other devices

※ Example for application :

1. PACKING EQUIPMENTS FOR MANUAL WEIGHING
2. EQUIPMENTS FOR AUTO-FILLER WEIGHING
3. EQUIPMENTS FOR OUTPUT WEIGHING
4. EQUIPMNETS FOR ACCURACY WEIGHING
5. RECORD-MANAGEMENT FOR PRODUCT WEIGHT

☞ REMARK

- Specification subject to change for improvement without prior notice.
- If changing,the Version No can be increased,but keeps a former version
As far as possible

1-2. SAFTY CONDITIONS

Please keep the following using conditions certainly

◆ EARTH

To avoid an electric error such as a noises in your production line
It should be earthed before installation certainly.
Specially it will be safty to devide the power of Indicator into a load cell.

◆ SAFTY CONDITIONS

Don't use it closed to a explosive gas and an inflammable dust environments

◆ POWER

Use the power under 110/220V 50/60HZ ±10% and devide it into the power line

◆ TEMPERTURE CONDITIONS

OPERATING TEMPERTURE : -10o C ~ +40o C (+14o to 104o F)

CUSTODY TEMPERTURE : -40o C ~ +80o C (-40o to 176o F)

◆ INSTALLATION LOAD CELL

- Available to use the same load cell of 8pcs (300Ω standard)
- A ground should be installed horizontal
- Installing over 2pcs of load cell, please connect each line in parallel and Insert a variable resistor under 50Ω in EX + line and minimize a output Accuracy of load cell.
It may occur a weight error by each accuracy of load cell.
- It may occur a weight error in case of a temperture variation of load cell
- Please weld(electospark) at the place installed with load cell and equipments, Devide the power into a connector of load cell in inevitable case
- Please connect the below construction of load cell with the above ones using The earch to the weighing part weighing a materail occuring a electrosparks.

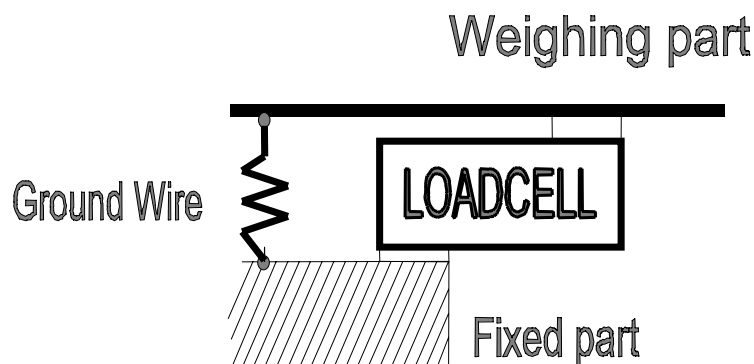

1-3. FEATURES

- A compact Apperance by DIN regulations (DIN 192 × 96 Panel system)
- Easy to preset,change,confirm the weight value by the numeral key.
- Improved a convenience and precision of operating with Message Function.
- Can display a various infomation using F1,F2,F3 key for the end-user.
- Can use or disuse each key function. (SETUP F10 Reference)
- Weight Memory function even in electrospark case (SETUP F02 Reference)
- The permit or prohibition function of Calibration (ADJUST 10 NO Switch)
- Watch-Dog timer guards for self-diagnostics.
- Set up to 1/20,000 display resolution
- Functio available to change the unit value such as kg, ton, lb ,g
(In case of Serial Communication & Printer)
- Available to change the function of the external input terminal (SETUP F16 Reference)
- Various option and addition for customer's satisfaction such as serial communication, RS-422/485, Current Loop, Printer, Analog out, BCD Input/Output and so on.

1-4. FRONT PANEL DESCRIPTION

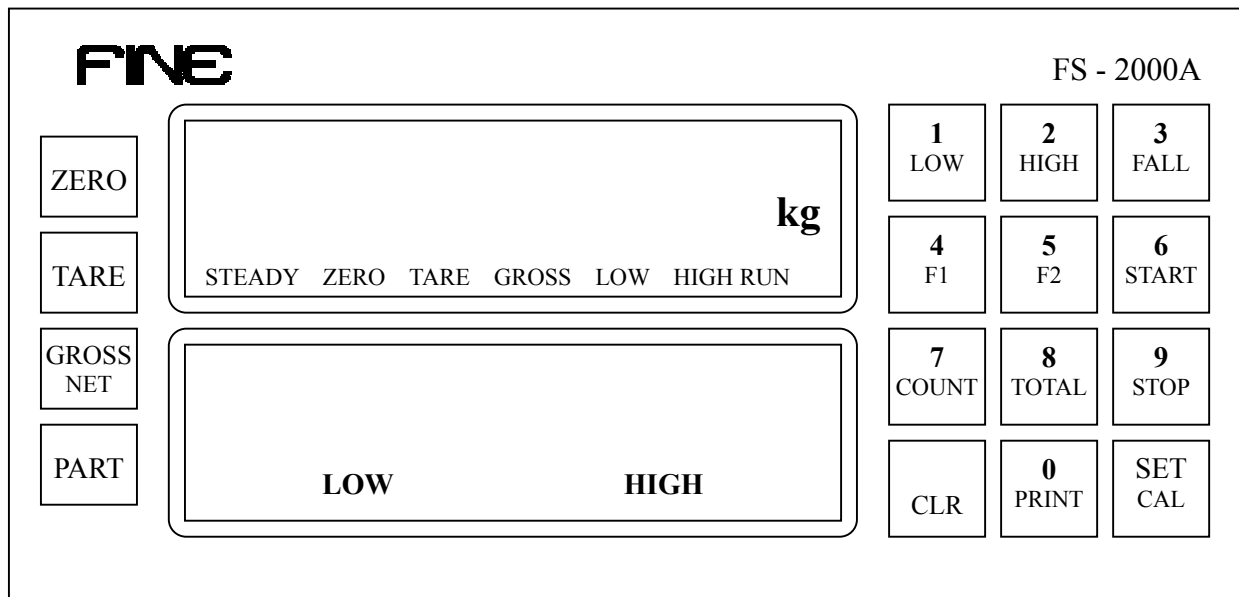

1-4-1. LAMP

- ▼ STEADY : This Lamp will be turned on the stable weight
When presetting and working a auto-function, this STEADY Lamp will be the weighing standard. .
- ▼ ZERO : This Lamp will be truned when the weighing device is empty.
When presetting and working a auto-function, this ZERO Lamp will be the weighing standard.
- ▼ TARE : This Lamp will be switched to Net mode
(SET-UP F12 REFERENCE)
- ▼ G/W : This Lamp will be turned on the gross weight
When presetting a TARE, It will be a Lamp Function.
- ▼ LOW : This Lamp will be displayed when Weight is in LOW weight range.
- ▼ HIGH : This Lamp will be displayed when Weight is in HIGH weight range.
- ▼ RUN : This Lamp is being running by the start of Sequence Board.

1-4-2. HOW TO USE KEY

* **The Key operating can be permitted or prohibited by SETUP-F10**

* **When pushing the key,it sounds "OK".**

* **Each Key works either a single function or compound functions.**

A compound function key will be a command key when it push first and

According to the command key,the fixed value works its function,

The key to finish a input data is **SET Key**.

* The input time of compound key is limited with 5sec and automatically will Be removed without the next key input.

☞ **ZERO Key** : This key returns the display to the center of ZERO when the weighing device is empty(the end-user selected within 2%, 10%, 50%, 90% by SET-UP F07)

☞ **TARE Key** : The way to set-up the tare weight is two way as follows.

- Manual Way

1.Set-up of TARE Key

① Put a TARE on the weighing plate

② TARE Key →SET Key OR TARE Key → Numeral Key → SET Key

2.Remove of TARE Key

① Remove TARE on the weighing plate

② Push TARE Key and push SET Key.

- Automatic Way

1.Auto-TARE setting if TARE was on the weighing plate

2.Auto-TARE setting after putting TARE and Auto-TARE Remove

After Taking away TARE on the weighing plate.

※ Please refer to **SETUP F12**

☞ **G/W Key** : After setting TARE, Net Weight converts Gross weight,
OR Gross weight converts Net Weight

* Available to convert setting TARE only.

☞ **PART Key** : Usable to confirm or change the product part

* Can set up the data of each product from 1 No to 20 No.

- Confirmation PART : PART Key → CLR Key

- Changing PART : PART Key → Numeral Key →SET key

☞ **LOW key** : This key to input the low weight

LOW key → LO-SET → Numeral Key →SET key(Reference F40 Control System)

☞ **HIGH key** : This key to input the High weight

HIGH key → LO-SET → Numeral Key →SET key(Reference F40 Control System)

☞ **Fall Key : Can preset a Fall weight**

Preset + (FALL Number) + SET

☞ **F1,F2,Key** : This keys appear a various data as the end-user demands.

Available to use the end-user demanding by SETUP F21,F22,F23
(SET UP F21 REFERENCE)

- ☞ **TOTAL Key** : The function to delete and print SUB-total and TOTAL
- * Delete : **CLR + TOTAL + SET(SUB-total Delete)**
CLR + TOTAL + TOTAL + SET(TOTAL Delete)
 - * Deleting TOTAL, SUB-total delete automatically.
 - * **Print: TOTAL + PRINT (SUB-total PRINT)**
TOTAL + TOTAL + PRINT(TOTAL PRINT)
 - * Possible to delete automatically when printing (SETUP F18 REFERENCE)

- ☞ **Start / Stop Key (refer : F40)**
- Can use start & stop a weighing work.
- * Please use CLR + Start Key to stop a weighing work.

- ☞ **PRINT Key** : This Key is to Transmit, Totalize, Print a DATA
- * Unavailable to work it while Auto Mode
 - * Please push **CLR + Print when deleting the last TOTAL date.**
Only Unavailable to re-power, change the PART, Available 1time only
(The last total data will be deleted also on Auto-total)

- ☞ **CLR Key** : This have 4way to use as follows .
- 1) When cancelling it with inputing the setting value
 - 2) **CLR + TOTAL(+TOTAL) +SET** When setting the total data.
 - 3) **CLR + Print when deleting the last TOTAL date**
 - 4) When using SETUP or CALIBRATION (3Chapter, 4Chapter REFERENCE)
- * After CLR Key, If no a additional data, it will be deleted automatically. .

- ☞ **SET/CAL Key** : **SET** key have 2way to use as follows
- 1) When recording each setted data
 - 2) When using SETUP or CALIBRATION(3Chapter, 4Chapter REFERENCE)

1-5. REAR-SIDE PANEL

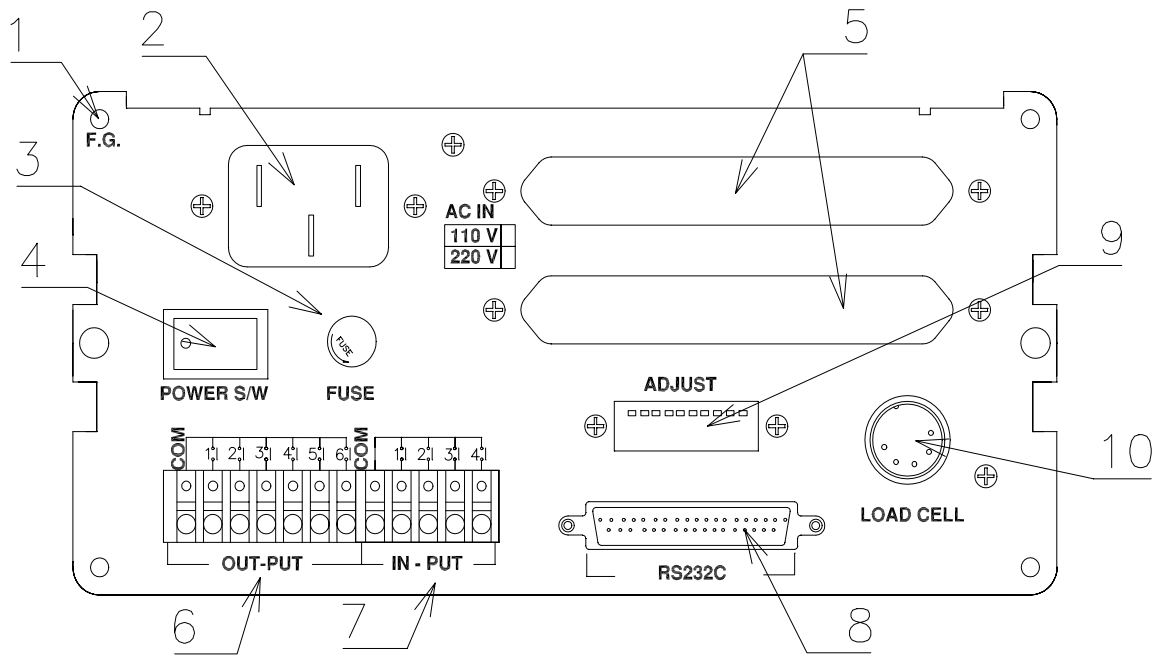

1. F.G. : Please earth it for safe.

2. AC IN : Available to change AC110/220V with multiple.
 Before setting up, please confirm the power voltage.
 Please change the connect terminal of 110V/220V after opening the cover
 If you need to change. (It was setted with AC220V at the first)

3. FUSE : please use the standard approved .
 (FUSE) AC250V, 0.3A (a glass tube with small type)

4. POWER S/W) ON/OFF

It will be safe to use it after 10minuate for a precise measurements

5. DATA OUT (OPTION BOARD) :

Serial Communication.RS422, BCD OUTPUT, Analog Voltage,
 Electric Curnnet(Analog Out) 0-10V or 4-20mA, Print Out

6. OUT-PUT : Connect between COM terminal and OUTPUT terminal

With the earth of no electric power, please use the output data
 For a signal only, don't use it for working.

Max earth capacity : AC250V / 0.5A

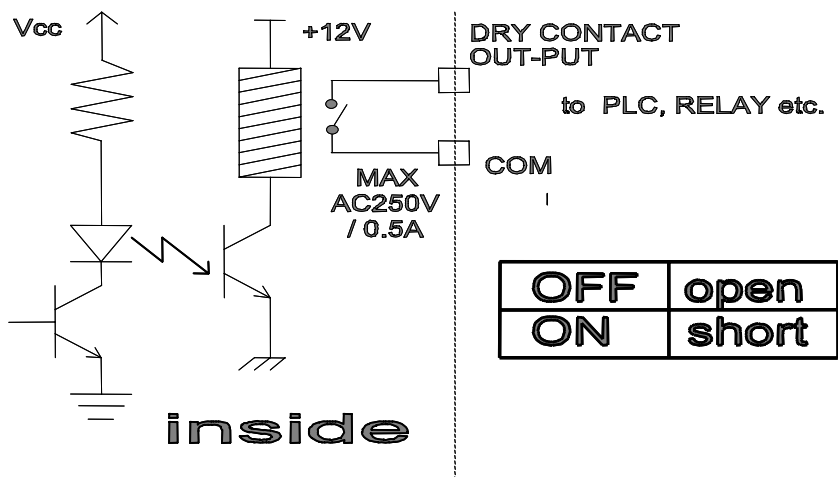

7. IN-PUT : This key is to control a equipment from the outside .
 The functions of input terminal is to choose it by SETUP F16
 Please connect between COM terminal and each input terminal .
 Because the power of input terminal was connected with 12V voltage
 From the inside.

- * An electric current is about **10mA**.
- * **Please make the Minium time to input a data with over 50mSEC.**

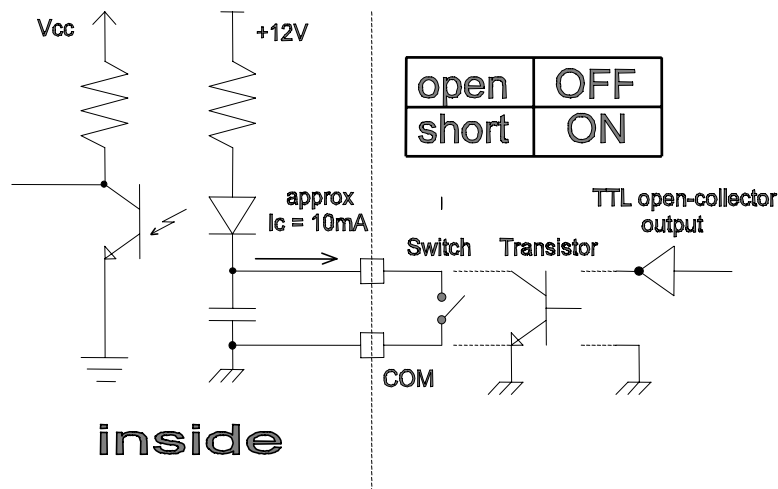

8. RS-232C (25P D-type Female) : (OP-01)

9. Loadcell Connector(N-16)

- ① EX+ (+5V) ② EX- (-5V) ③ SIG+
- ④ SIG- ⑤ SHIELD

10. ADJUST : DIP Switch for ZERO and SPAN Control
 (1-6No : ZERO , No 7-8 : SPAN , No 10 : Calibration Lock
 Functions of each input terminal is to choose SETUP F16.

1-6. SPECIFICATION

1. Analog Input & A/D Conversion

Input Sensitivity	0.2 $\mu\text{V}/\text{D}$
ZERO adustment Range	-4mV ~ 42.0mV
Load cell excitation	DC 10V (± 5 V)
Max Input voltage	32mV
Temperature Coefficient	± 20 ppm / $^{\circ}\text{C}$
INPUT Noise	± 0.5 μV P.P
INPUT Impedance	10 $\text{M}\Omega$ (MAX)
A/D Converter	130,000 Count
Non-Linearity	0.005% F.S

2. DIGITAL SECTION

MAX.DISPLAY	"1000000"
MIN.DIVISION	x1, x2, x5, x10, x20, x50
DISPLAY UNIT	7-Segment, 7digit Highly bright fluorescent tube
KEY BOARD	Numerical Key and Function Key(0-9,CLR,SET/CLR)
Data Back-up	APPR.10 YEAR

3. GENERAL

POWER	AC110 / 220V ($\pm 10\%$), 50 / 60Hz, 10VA
PRODUCT WEIGHT	NET 2.3kg BOX 3.3kg
Operating Temperature	-10 $^{\circ}\text{C}$ ~ 40 $^{\circ}\text{C}$
Operating Humidity	85%RH MAX (Non-Condensing)
Physcal Dimmensions	193.6 x 98 x 166 (mm)

4. OPTION

OP-01	STANDARD
OP-02	Serial I/F : CURRENT LOOP
OP-03	Parallel I/F : BCD Out
OP-04	Serial I/F : RS422, RS485
OP-05	Analog Output : Vout (0-10V / 10V-0V)
OP-06	Analog Output : Iout (4-20mA / 20-4mA)
OP-07	Print I/F : CENTRONICS Parallel
OP-10	Parallel I/F : BCD In PART

1-7. The example for the connecting to external devices

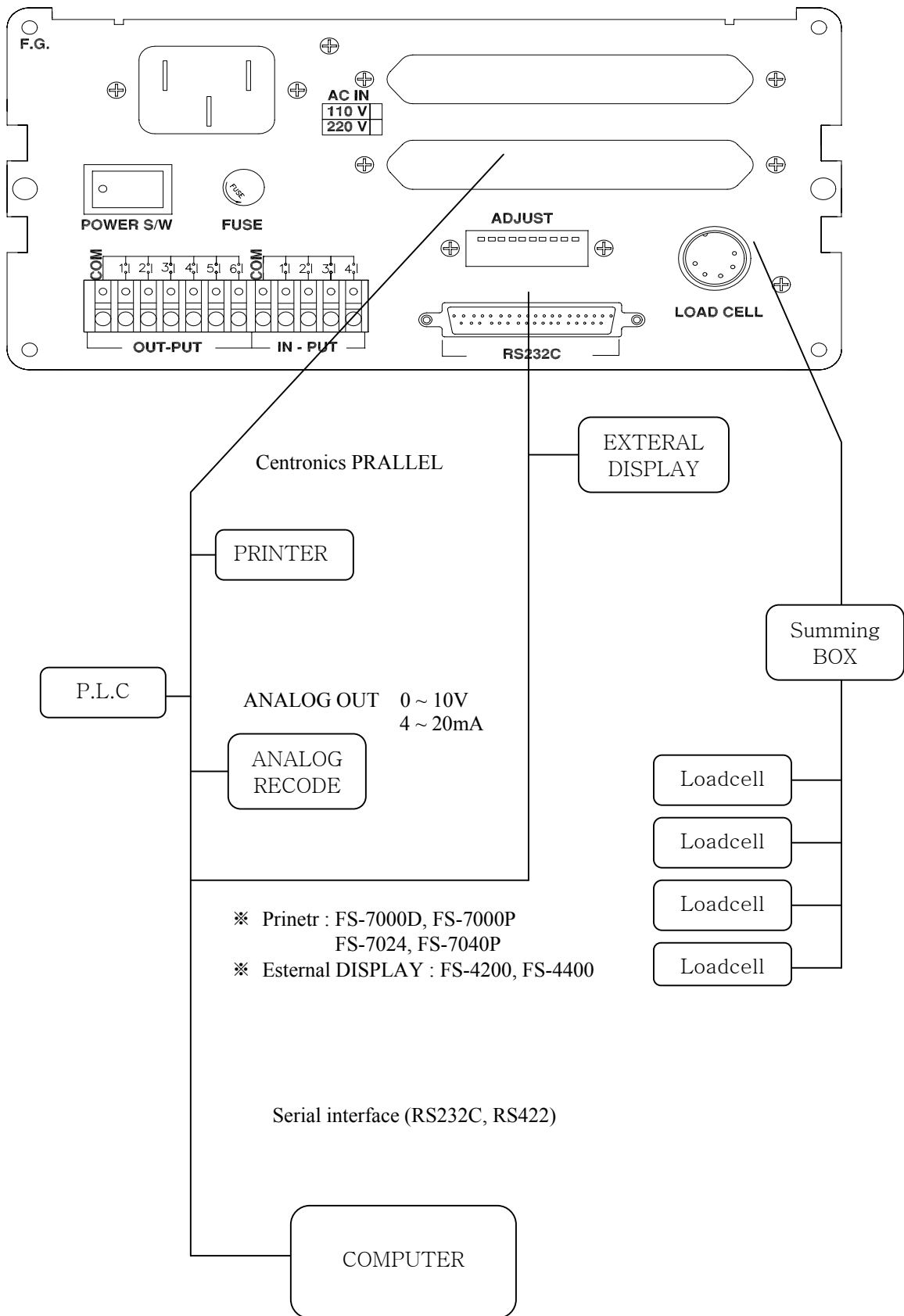

CHAPTER 2. INSTALLATION

☞ GENERAL RULES

- Avoid sudden Collision, vibration, temperature, water, wind
- Use a stable power supply 110V/220V \pm 10% 50/60Hz - Set up voltage **220V**
(Adjust the power voltage because the choice terminal of power is inside.)
- Connect and power off the switch when connecting the external equipments.
- Ensure to earth Indicator to equipments
- Ensure to calibrate and set up it for operating.

* PARTS

- POWER CODE : 1EA
- FUSE : 2EA (PIPE TYPE 250V 0.3A SMALL TYPE)
- LOAD CELL CONNECTOR : 1EA (N16-05)
- OPERATING MANUAL : 1EA
- A Stable Connector for Option installation.

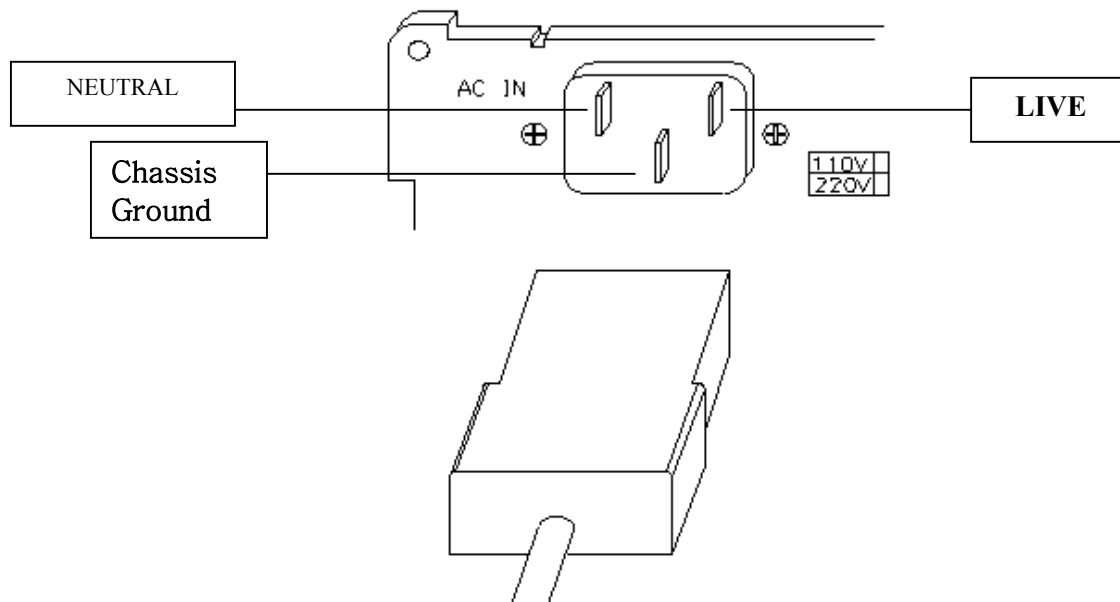

※ The connection of power cable

2-1.Out-Dimension & Cutting Size

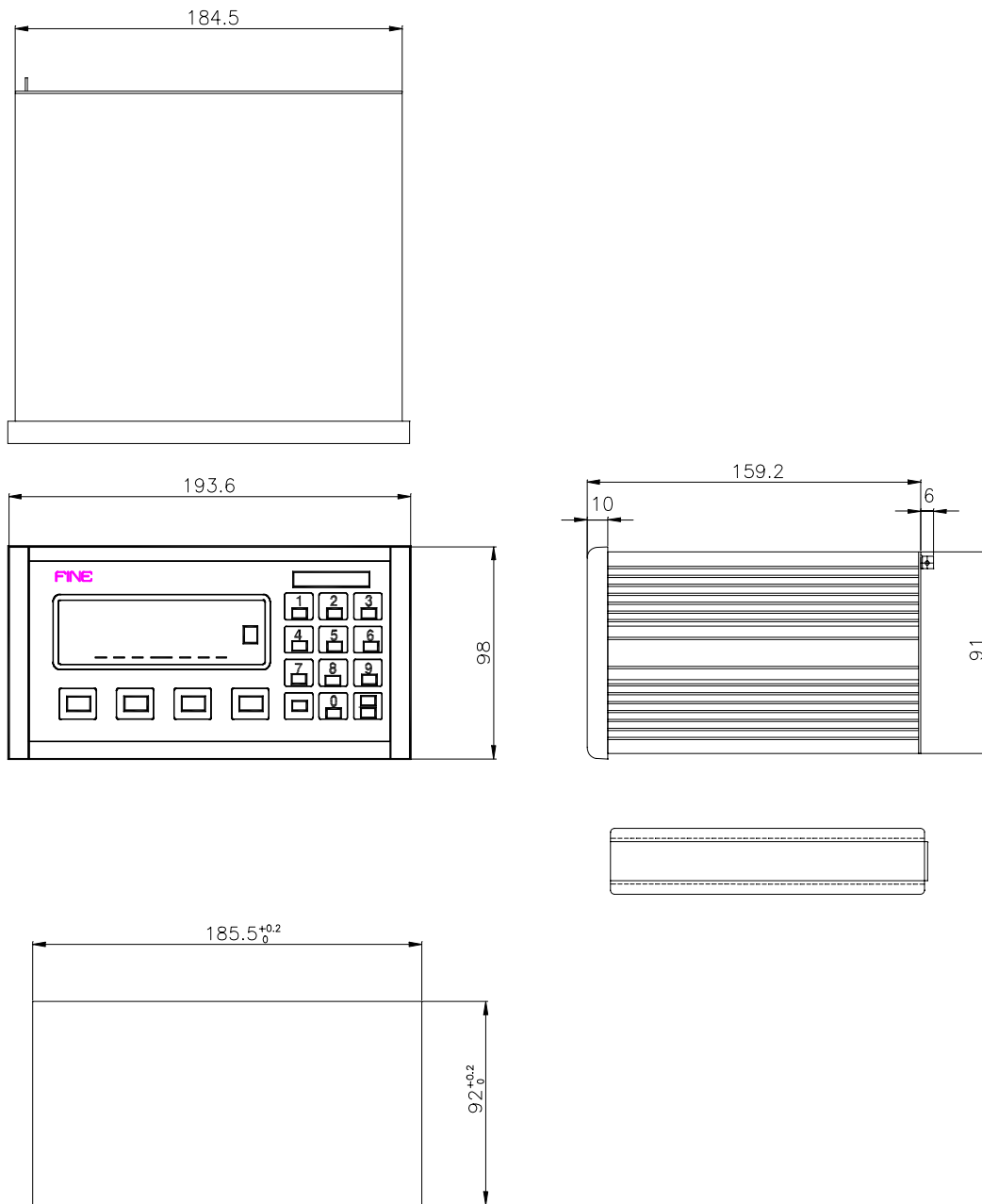

2-2. ASSEMBLE DRAWING

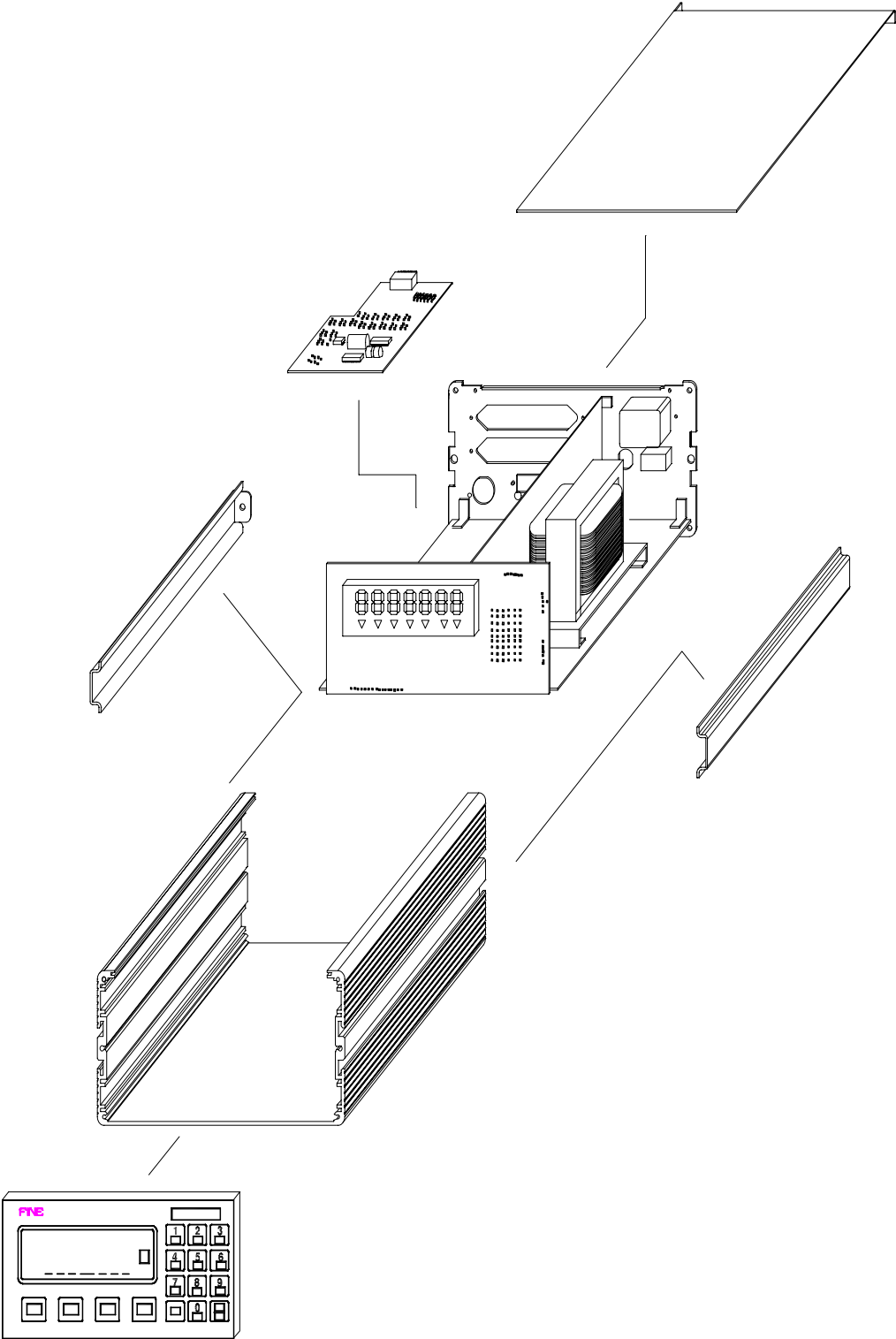

2-3.HOW TO CONNECT LOAD CELL

1. STABLE LOAD CELL

The output power of load cell which was used with the weight sensor is
 $1\text{mV/V} \sim 3\text{mV/V}$

▣ **The output voltage of load cell is not absolute value but relative value.**

Ex) if Max.load was connected to 3mV/V output 10kg&10ton load cell,
 The Output Voltage is the same with 3mV/V

2. Load cell Connector

* Please connect the indicator connector with the wire of load cell
 According to the color.

*Possible to connect the load cell of the same kind in parallel up to 8pcs.(Max 300Ω)

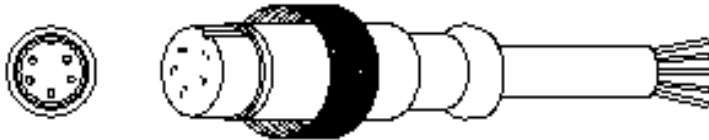

3. The wire color of load cell according to manufacturer.

	1 EXC+	2 EXC-	3 SIG+	4 SIG-	5 SHLD	Remarks
FINE INDICATOR'S WIRE COLOR	RED	WHITE	GREEN	BLUE	SHIELD	
BONGSHIN, CAS, TMI, AND	RED	WHITE	GREEN	BLUE	SHIELD	
DAESUNG LOAD CELL	RED	BLACK	WHITE	GREEN	SHIELD	
JUNGSAN	RED	WHITE	GREEN	BLACK	SHIELD	
DAISOCELL	RED	BLUE	GREEN	WHITE	BLACK	
DANA	RED	WHITE	GREEN	BLUE	SHIELD	
BLH	GREEN	BLACK	WHITE	RED	YELLOW	
INTERFACE	RED	BLACK	GREEN	WHITE	SHIELD	
KYOWA	RED	BLACK	GREEN	WHITE	SHLED	
P.T.	RED	BLACK	GREEN	WHITE	SHIELD	
SHOWA	RED	BLUE	WHITE	BLACK	SHIELD	
SHINKOH	RED	BLACK	GREEN	WHITE	SHIELD	
TML	RED	BLACK	WHITE	GREEN	SHIELD	
TEAC	RED	BLUE	WHITE	BLACK	YELLOW	
HUNTLEIGH	GREEN	BLACK	RED	WHITE	SHIELD	

※ Load cell Connector Standard : N16-05

※ Because Wire color may be different as a manufacturer and load cell models.
 Please refer for the data sheet of load cell.

2-4. ERROR & A/S

ERROR	CAUSE	A/S	Reference.
Waving a weight Value.	<ul style="list-style-type: none"> ① Load cell damage ② Insulation resistance badness of load cell. ③ Weighing part error 	<ul style="list-style-type: none"> ① Checking for Input, Output of loadcell. ResistanceValue. ② Checking Insulation Resistance value of Load cell. 	<ul style="list-style-type: none"> ① Input resistance : about 420Ω ② Output resistance : about 350Ω ③ Insulation Resistance : over100MΩ
A. Changing a Weight value, B. Not return to ZERO	① Load cell damage.	① Checking Insulation Resistance value of Load cell. (Normal Max 100MΩ or -OL-appear)	
	① Disconncted to Load Cell.	<ul style="list-style-type: none"> ① Confirm a connect of Load cell ② Checking a single wire Of load cell cable 	
Weight (-) changed	① Load cell output (SIG+,SIG-)changed.	① Load cell connector	ERR-55 occurrence
Appear "bAd" on self-diagnosis	① Disconnect to Load Cell Damage	<ul style="list-style-type: none"> ① Load cell damage ② Load cell connector 	
	① Excess a range of Zero value.	① Zero adjustment. (5000-15000)	
Appear "UL" (UNDER LOAD)	① Load cell damage. Disconnect to Indicator.	<ul style="list-style-type: none"> ① Load cell damage ② Load cell connector 	
	① ZERO adjustment.	① Zero adjustment. (5000-15000)	
Appear "OL" (OVER LOAD)	<ul style="list-style-type: none"> ① Load cell damage ② Connection Error 	<ul style="list-style-type: none"> ① Load cell damage ② Load cell connector 	
	① Excess Max weight	① Remove excess weight	

CHAPTER 3.CALIBRATION

▣ *What is Calibration?*

Cablration is to adjust Max.weight,minium division,decimal point displaid to Indicator To the actual weight worked by load cell.

☞ *It should calibrated certainly when load cell or indicator will be changed.*

3-1. ZERO ADJUSTMENT

▣ *What is zero adjustment.?*

The meaning of ZERO is the fiducial point of weighing operation.

In case a zero value is less than normal operating zero range,

The indicator will be displayed to "UL".

The other side, it will be displayed to "bAd".

Then,it will be not operated normally

☞ ZERO POINT RANGE

Adjust the value displayed to " test1" closed to 1000 - 20000 (Recommand5000)
(Dip-switch 1-6)

※ ZERO POINT ADJUSTMENT REFERENCE AS FOLLOWS

1. HOW TO ADJUST ZERO POINT

Please turn on while pushing **1** key after turn off

The display was displayed as follows

tESt

Push **1**key again,Indicator displays zero value after displaying " test1"

Then,if an zero value was not displayed or displayed with " test1" only

Or not Displayed any number,Turn on the dip-switch(1~6)of the real panel,

Adjust the dip-switch that The number appearing on the display should be closed to 5000.

(Example)

While pushing **1**key + Power turn on -> tESt
While displaying tESt + **1**key,puse **1**key again.
Then this value will be zero value.

2. How to adjust a dip-switch.(Adjust at the real panel.)

Narrow range change			Wide range change				a multiple of zero adjustment	changed range
	1	2	3	4	5	6		
1	ON	ON	ON	ON	ON	ON	0	0
2	OFF	ON	ON	ON	ON	ON	1	-980 changed range
3	ON	OFF	ON	ON	ON	ON	2	-1960 changed range
4	OFF	OFF	ON	ON	ON	ON	3	-2940 changed range
5	ON	ON	OFF	ON	ON	ON	4	-3920 changed range
:	:	:	:	:	:	:		
62	OFF	ON	OFF	OFF	OFF	OFF	61	-59780 changed range
63	ON	OFF	OFF	OFF	OFF	OFF	62	-60760 changed range
64	OFF	OFF	OFF	OFF	OFF	OFF	63	-61740 changed range

Indicator have the adjust cover on the rear-panel.

Opening the cover,10EA of dip-switch is in this cover.please adjust the zero value with adjustment key

1 ~ 6No of dip-switch closed bewteen 5000 and 15000

Don't use the 7.8No of dip-switch when adjusting a zero point.

10No dip-switch is to adjust the calibration (ON: prohibition,OFF: permission).

(Example)

Question: At present 27300 and dip-switch all condition "ON".

Answer : If 1No of dip-switch was OFF,also the changing range was 980,

The changing range of Each dip-switch is as follows

Dip-switch	1	2	3	4	5	6
Changed range	980	1960	3920	7840	15680	31360

If 1,2,3,5 dip-switch was OFF,the changed range is $980+1960+3920+15680=22540$.

As the result of,it will come to $27300-22540=4760$ and will result in about 5000.

3-2. SPAN ADJUSTMENT

▣ *what is span adjustment.*

Span adjustment is to make the display value from "0" to max.weight consistent to
The actual weight

※ Please do **OFF** NO 10 of dip-switch(Calibration Permittion)

▶ **How to access the SPAN ADJUSTMENT.**

There are 2ways to access the span adjustment

☞ **The first way**

Turn on the power while pushing **Ⓜ**Key.then,the display will be "tEST"
Then,pushing **Ⓜ**Key again,it will be displayed with "St. CAL"
Also,pushing **SET/CAL** on the below right. it will be displayed with "d xx"
("xx" means 01, 02, 05, 10, 20, 50)

(Example) POWER OFF CONDITIONS

- | | | | |
|--------------------------------------|-------|------------|------------------|
| 1. While pushing Ⓜ Key | ----- | Display is | "tEST" |
| 2. Pushin Ⓜ key again. | ----- | Display is | "St. CAL" |
| 3. Pushing SET/CAL key | ----- | Display is | "d 02" |

☞ **The second way**

- ① If pushing **SET/CAL** key for 3sec,it will be displayed "St. CAL"
- ② "**St. CAL**" means SETUP & CALIBRATION mode

▶ HOW TO ADJUST SPAN.

S&C MODE have 7way to adjust span. each step will be advanced with **SET/CAL key**. Also, **CLR** key was used to return the prior conditions.

- ※ F.F : **SET/CAL** key
- ※ Review : **CLR** key

☞ 1Step.

A step to set up a division value and decimal point.

"d" means "Division" and "xx" means a division capable of displaying.

Also this value will be displayed as 01-02-05-10-20-50 by each key.

In case decimal point is "0.0", it will be 2

In case decimal point is "0.00", it will be 3

In case decimal point is "0.000", it will be 4

If decimal not, push 1 key and **SET/CAL key**,

So, it will be go to the next step recording the position of decimal point.

☞ 2Step

A step to set up max.weight.

The display will appear "**CAPA**" (Capacity) and discretion number (max. 6 figure)

It can input the maximum weight as the end-user demands instead of discretion number.

How to input is to push **SET/CAL** key after inputting discretion number.

♣ Don't excess (A division \div Max.weight) with over **1/20,000**

If excessing over **1/20,000**, it will appear "**Err 01**".

☞ 3Step

A step to check the zero conditions of Indicator.

After appearing "**dEAd**", the discretion number (Max. 5 figure) will appear.

If the present number is closed by 5,000, please push **SET/CAL key**.

If a discretion number don't appear and is over 20000,

Please do it as the zero adjustment instruction.

4Step

Indicator will display the capacity at weight column which was set at 2 step after being displayed " S P A n " .

Please input the value of standard weight for span adjustment by numeric key. This value of span standard weight must be equal to full capacity, or over 10% of full capacity.

(In case of less 1/5,000 resolution ,the value of standard weight must be over 10% of full capacity at least.)

(In case of over 1/5,000 resolution ,the value of standard weight must be over 20% of full capacity at least.)

(Notice) If span capacity is set less 10% ,indicator will display error message.

(E r r 0 2 or E r r 0 3)

5Step

Please put the span standard weight on the platform.(the weight is 1000kg at here) Press SET/CAL key after stable of platform.

(Notice) If indicator is unmatched with load cell capacity or span standard weight, indicator will display error message (E r r 0 4)

6Step

Indicator will display any constant value of span adjustment.

If the range of this constant value is between 0.5000 -- 3.50000,

All procedure of span adjustment is normal.

And then,press SET/CAL key for next procedure.

If you remember this constant value , you can adjust the span without standard weight by F99 (Function number 99) at set-up mode.

(Please remember this constant value,full capacity and one digit for your further calibration & reference)

7Step

The "END" message is displayed in 6 step,

all span adjustment is end.

Press SET/CAL key after put down of span standard weight on the platform.

The indicator will enter into user's weighing mode.

■ For Example of SPAN ADJUSTMENT

- * Max.Display Division : 50.00kg
- * Display Setting Interval : 10g
- * When the 10kg of standard balance was prepared.

First Condition	S&C Choice Mode	St. CAL
1 STEP	Pushing SET/CAL Key	d 50
	Ajusting a interval pusing ⓪key	d 01
	Setting a decimal pushing ⓪key	d 0.01
2 STEP	Pushing SET/CAL Key	80.00 CAPA
	Pushig a Numeral Key ⓪⓪⓪⓪	50.00 CAPA
3 STEP	Pushing SET/CAL Key	4879 dEAd
	※ If a display value was not between 1000-20000, It should adjust ZERO.	
4 STEP	Pushing SET/CAL Key	50.00 SPAn
	Pushig a Numeral Key ⓪⓪⓪⓪	
5 STEP	Pushing SET/CAL Key	Load
	Loading a balance on the weighing part.	
6 STEP	Push SET/CAL after 3sec till The weight will be safty	0.97482
7 STEP	Pushing SET/CAL Key	End
	Push SET/CAL key After unloading a balance	"FlnE" after checking inside ZERO & 7 Segment display
	In the weight display	If it display 0.00 It will be normal

3-3. ERROR MESSAGES & OPERATING

-- tEst or FS-XXXX : If indicator display only " tEst " or FS-XXXX (Model number) without any operation ,first of all you must adjust "dip switch" of back side panel for span and zero value.

--Err--01 : Set over 1/20,000 resolution.

--Err--02 : The value of span standard weight is higher than full capacity of scale.

--Err--03 : The value of standard weight is less than 10% of full capacity.

--Err--04 : Unstably calibrated span in the above 5 step.

--Err--05 : The span standard weight is higher than set-up weight of it.
Please confirm whether span standard weight is same as set-up weight of it.

If indicator display error message continuously,
Please adjust dip.switch no.7 or 8 in rear panel.
(Notice:After adjusting of dip.switch.
Please confirm again about zero value.)

* DIP.S/W ARRANGEMENT FOR ADJUSTING SPAN VALUE

NO 7	NO 8	SIZE OF SPAN	
ON	ON	SAMALL	1TIME
OFF	ON	NORMAL	2TIMES
ON	OFF	BIG	3TIMES
OFF	OFF	VERY BIG	4TIMES

OFF



ON

If indicator display error message continuously after adjusting of dip.switch,
Please confirm about the connection status of "exc+ and exc-" in load cell cable.

--Err--06 : The span standard weight is lower than set-up weight of it.
Please confirm whether span standard weight is same as set-up weight of it.

If indicator display error message continuously,
Please adjust dip.switch no.7 or 8 in rear panel.
(Notice:After adjusting of dip.switch.
Please confirm again about zero value.)

* DIP.S/W ARRANGEMENT FOR ADJUSTING SPAN VALUE

NO 7	NO 8	SIZE OF SPAN	
ON	ON	SAMALL	1TIME
OFF	ON	NORMAL	2TIMES
ON	OFF	BIG	3TIMES
OFF	OFF	VERY BIG	4TIMES

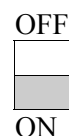

If indicator display error message continuously after adjusting of dip.switch,
Please confirm about the connection status of "exc+ and exc-" in load cell
cable.

--Err--07 : Input of the wrong data at set-up mode

--Err--10 : Error for memory record or hardware device.

-- "UL" : Error for a load cell connection or load cell down.
Dip-switch adjustment.

-- "OL" : Error for a load cell connection or load cell down.
overload for the weight

CHAPTER 4. SET-UP

4-1. PREFACE

-- The meaning of " SET-UP " :
is to choose each proper functions for matching the indicator with the appliances of field.

* How to enter into set-up mode

This set-up mode is required for proper weighing operation when indicator connect with other appliance.

You can enter into sep-up mode by below two methods.

- 1) Depress key "3" first and power on at the same time.
At that time," test " word will be displayed on indicator.
Depress key "3" again, and indicator will display as following :

S t, C A L. ; S & C Mode

At this time,press CLR key.

Indicator will display to " F01-xx " from above test message.

- 2) If you depress key " SET/CAL " for 5 seconds at the normal weighing mode, indicator will also display above.

4-2.SET-UP

If you press key " CLR " at S & C mode, indicator will display as following:

F 0 1 - X X

.
. .
.

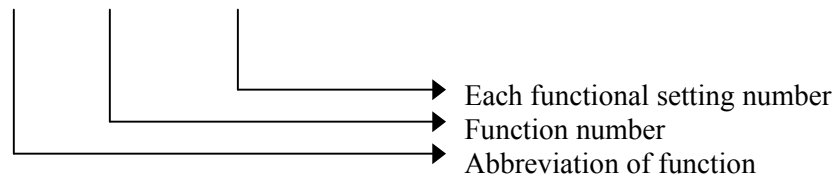

---Setting method :

- 1) If you proceed to next function,press CLR key or,
If you want to see your desirous any function number,
Press "CLR" key after input any function number by numeric key.
Indicator will display function number directly from present function number.

(EXAMPLE)

- * Present display : F01-01
Press CLR key ----> "F02-00" display ----> Press CLR key.
----> "F03-01" display ----> Continuously press CLR key ---->
"F04-XX" ----> "F05-XX" ----> "F06-XX" ---->

Press CLR key in streams, the next function number will be displayed.

- * Present display : F01-01
If you want to see function number 12,
Press numeric key "1" and "2" ----> Press CLR key ----> "F12-XX" display

- 2) IF you want to change each functional setting number newly,
Press SET/CAL key after input the functional setting number by numeric key.

(EXAMPLE)

If "F01-01" is changed to "F01-03",
Press  key ----> F01-03 display ----> Press SET/CAL key.

A new function number will be memorized.

(Remarks) When you want to change " S & C MODE " from Set-up mode,
Please press key " 0 " + " CLR " consecutively.

4-3.F-FUNCTON LIST

F-NO	FUNCTION	CONTENTS
F-00 GROUP-SETTING A BASIC WEIGHIG		
F 00	S & C MODE Convert	SETUP & CALIBRATION
F 01	weight unit choice	kg, ton, lb
F 02	weight BACK-UP	NORMAL, BACK-UP
F 03	Set ZERO tracking Range	0, 0.5, 1, 2
F 04	Set Safty Motion Band	0.5, 1, 2, 4, 8
F 05	Set AUTO ZERO Range	0-99 (Auto Zero Range)
F 06	Digital Filter	0-9 (anomalous decrease)
F 07	Set ZERO Range	Max.weight 2, 10, 50, 90%
F 08	Set Delay time of Safty judgement	0-99 (1count = 0.1sec)
F-10 GROUP-SETTING A BASIC DEVICE		
F 10	Selecting a Key Lock	Prohibition & Permit for KEY
F 11	ZERO,TARE,OPERATE MODE	Satty,Unsafey
F 12	TARE weight INPUT MODE	Set Numeral,Actual,Auto TARE
F 13	EMPTY Signal MODE	Output Choice when it is ZERO or Empty
F 14	SET EMPTY Range Set	Set Empty Range Weight
F 15	SET EMPTY Standard Set	Display weight,basic ZERO,TARE ZERO
F 16	External INPUT MODE	Input terminal function
F 18	DELETE Totalization information	Delete in Manul/ Auto for totalization
F 19		
F-20 GROUP-SETTING CONTROL SYSTEM		
F 21	User key definition	No definition or Set
F 22	User key definition	No definition or Set
F-30 GROUP-SETTING Serial Interface Specification		
F 30	BRUD RATE	300, 600, 38.4 kbps
F 31	Set Parity Bit	EVEN, ODD, NO PARITY
F 32	Set Transmit MODE	Continue,Satty,Totalization,Command.
F 33	Set Format Transmit DATA	weight, weight+time, CAS tranmit format
F 34	Insert Transmit DATA (STX)	No, Insert
F 35	Control Interface wire / RS,CS	No use(RS422/485), USE
F-40 GROUP - CONTROL MODE		
F 40	Set - up For Controlling Weight	Simple / Sequence / Check Mode Control
F 41	Delay time for Finish Signal	0 ~9.9 sec set
F 42	Maintaining time for finish signal	Continous or 0.1 ~ 9.9 sec set
F 43	Set for FALL Compensation	No use or 5,10,20,50 times
F 44	Set for Prohibited Time	No use or 0.1 ~ 9.9 sec set
F 45	Set for a weighing Range	+ range, Absolute,- range
F 46	Set for Finish Signal way	Manual,steady,steady+time,time
F 47	Set for disply weight way	No use,fixed display weight
F 48	Set for zero or tare of start	No use for a simple control mode

F-50 GROUP-SETTING BCD Output Specification		
F 50	Weight choice for output	Display,Gross,Net weight
F 51	BCD OUT Parity	Positive / Negative OUT
F-60 GROUP-SETTING Analog Out Specification		
F 60	Weight choice for output	Display,Gross,Net weight
F 61	Standard weight choice of Analog Out	Max,display weight,Standard weight
F 62	Analog Out Parity	Positive / Negative OUT
F 63	Standard weight Set of Analog Out	Set standard value of Max.OUT
F-70 GROUP-SETTING Printer Specification		
F 71	Set Printer system	Contine / Each
F 72	Set Line Feed after printer finished	1 Count = 1 Line (0~99)
F-90 GROUP-SETTING		
F 90	Set Device Identification No	00 ~ 99
F 95	DATE Modification MODE	yy-mm-dd in Printer option only
F 96	TIME Modification MODE	hh-mm-ss in Printer option only
F 98	Check A/D Count of Basic ZERO	Check load cell if it is normal or not

CHAPTER 5. SET-UP ILLUSTRATION

5-1. BASIC FUNCTION FOR WEIGHING

F00-	Setup & Cablibration Mode
-------------	--------------------------------------

Setting for position of decimal point		
F01-	⓪	kg
	1	Ton
	2	lb
	3	g

Back - Up of Weight Value		
F02-	⓪	NORMAL
	1	BACK-UP
<p>※ Normal : The Indicator willll not be done back-up weight when power is off or down</p> <p>※ Weight back - up : The Indicator will be done back-up of weight ILL B When power is off or down You must set this weight back-up after calibration of span at The normal mode.</p> <p>REMARKS : This weight back-up Mode must be used after span adjustment.</p>		

Setting of zero tracking range		
F03-	0	No ZERO TRACKING
	⓪	0.5 DIGIT / 0.25sec
	2	1 DIGIT / 0.25sec
	3	2 DIGIT / 0.25sec
<p>※ What is ZERO Tracking ? If A weight continue to change with a small value, It displays the weight in spite of No product on the weighing part. It is to compensate such a value.</p>		

Setting of motion band range			
F04-	0	0.5 Devision	※ Motion Band ? It means compensating a termpoary tramble If the weight change was less than the present set value for the time set by F-08, it will be a safty jusding.
	①	1 Devision	
	2	2 Devision	
	3	4 Devision	
	4	8 Devision	
This is to compensate for the momentary vibration value. If indicator is used in vibration area,please set enough motion band range			

Auto zero setting		
F05-	0 ~ 99	This is to make the weight of last two digits as zero automatically. * First Set 00
(Example) If the indicator is set to 15kg * 5g and f05-30 , The range of auto zero will be to 1--30g. At this time, F05 function is available up to 10 % of full capacity.		

DIGITAL FILTER			
F06-	0	LESS	Requesting a high speed respoose (0, 1, 2)
	~	↓	A general Weighing (3, 4,5,6)
	9	MORE	A greater vibrating (7,8,9)
If you use the indicator with conveyer belt system or any other vibrating appliance, this f06 function will be applied for filtering or absorbing the vibrating or oscillating weighing value.			

SET ZERO RANGE		
F07-	①	Under 2% of Maxium available weight
	1	Under 10% of Maxium available weight
	2	Under 50% of Maxium available weight
	3	Under 90% of Maxium available weight
Seting ZERO can be set in the range by ZERO Key or External ZERO Input Notice : Set Zero Ragne(50%),Load cell Capacity(100kg),Set Zero(50kg) Then,if the acutual weight is 100kg,it means weighing total 150kg On a load cell.So,The load cell may be broken. Please refer to Max.capacity of a load cell.		

Delay time for a steady judgment		
F08-	0	A weight is a deviation range set by F-04 and after time set, it will be a safety display and auto mode. * First Setting : 10 (1 sec) * 0.1sec Delay/per 1count
	~ 99	

5-2 . BASIC FUNCTION FOR DEVICES

SELECTING A KEY LOCK.		
F10-	⓪	Available to use all keys
	1	Unavailable to use all keys
	2	Unavailable to use ALL KEYS except of ZERO POINT KEY.
This function was designed to prevent from mis-operating by general user.		

ZERO & TARE KEY OPERATING MODE		
F11-	⓪	Zero & Tare KEY will be operated when a weight was steady.
	1	Zero & Tare KEY will be operated though a weight was not steady.

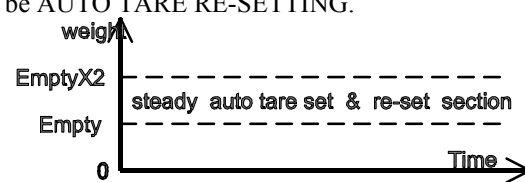
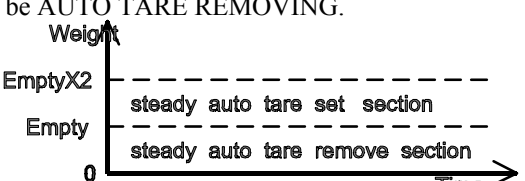
TARE WEIGHT INPUT MODE		
F12-	0	Setting TARE Value after inputting SET/CAL
	①	Setting TARE Value with inputting only by TARE KEY In the situation of putting a weight, tare On a weighing plate.
	2	<p>Auto Tare Setting if a weight was steady on EMPTY weight area. Under tare set-up situation, If Display Weight was steady under Empty Area, It will be AUTO TARE RE-SETTING.</p>  <p>(It is comfortable in case that TARE weight remove automatically before working and weighs it after working)</p>
	3	<p>If Gross Weight was steady under Empty area, It will be AUTO TARE REMOVING.</p>  <p>(It is comfortable in case that the filling works after loading TARE on the weighing part.</p>
* In case selecting NO 2,3, The TARE Key will be worked to NO 1		

EMPTY SIGNAL MODE		
F13-	0	If a weight is ZERO("0"),Empty signal will be showed.
	①	Empty Signal will be showed on a weight ("0" or "under 0")
	2	Empty Signal will be showed on a absolute value of Empty range
	3	It will be showed on "+range","-range".
* The occurrence of Empty will display ZERO LAMP		

SET EMPTY RANGE		
F14-	EMPTY RANGE	Through Setting Empty Range,AUTO Funtion (TARE,G/T,S/T,HOLD) will be used pratically. * FIRST SETTING 000010

SET EMPTY STANDARD		
F15-	①	Standard for a weight displayed .
	1	Standard for Basic Zero value .
	2	Standard for Zero value by TARE setting.

EXTERNAL INPUT MODE					
F16-		INPUT 1	INPUT 2	INPUT 3	INPUT 4
	0	ZERO	TARE	N/W	G/W
	1	ZERO	TARE	PRINT	NW/GW
	②	ZERO	TARE	START	STOP
	3	ZERO	PRINT	START	STOP
	4	Tare Remove	TARE	START	STOP
	5	G/W	N/W	START	STOP
	6	Tare Remove	TARE	PRINT	GW
* Input in connecting COM terminal and Input Terminal. The time to input is over 0.05 sec					

Delete Totalization Information		
F18-	①	Sub total Remove : CLR + Total + SET Grand total Remove : CLR + Total + Total + SET
	1	Auto deleting in printing Sub-Total,TOTAL

F1 KEY FUNCTION SETTING BY USER		
F21-	0	No AVAILABLE
	1	DATE
	2	TIME
	3	DATE & SETTING
	4	TIME & SETTING.
	5	S/T Working Number
	6	G/T Working Number
	7	S/T Weight.
	8	G/T Weight
	9	P.N Working Start DATE
	10	P.N Working Finish DATE
	11	P.N Working Start TIME
	12	P.N Working Finish TIME
	13	Display CODE No and Setting
	14	Setting Underweight Accuracy (F28 Reference)
	15	Setting Overweight Accuracy (F29 Reference)
F2 KEY FUNCTION SETTING BY USER.		
F22-	The above F1 FUNCTION SETTING is the same	
	0	No available
SET DEVICE IDENTIFICATION NO		
F90-	00 ~ 99	Unavailable for ID NO in cae of '00' setting. Available for ID NO in case of INPUTTING ID NO * First Setting 00

DATE MODIFICATION MODE	
F95-	<p>Example)</p> <p>Display "F01-00"</p> <p>Ⓣ key → Ⓢ key → CLR key</p> <p>In case of 97year 09month 30day → 2001year02month14day</p> <p>Ⓣ key → Ⓣ key → Ⓣ key → Ⓜ key → Ⓣ key → Ⓟ key → SET/CAL</p>
<p>* DATA & TIME was subjected to the OPTION setting.</p>	

TIME MODIFICATION MODE	
F96-	<p>Example)</p> <p>Display "F01-00"</p> <p>Ⓣ key → Ⓢ key → CLR key</p> <p>17hour 25min 30sec → 21hour 55min 56sec</p> <p>Ⓜ key → Ⓣ key → Ⓢ key → Ⓢ key → Ⓢ key → Ⓢ key → SET/CAL key</p>
<p>* DATA & TIME was subjected to the OPTION setting.</p>	

CHECK A/D COUNT OF BASIC ZERO	
F98-	<p>* This key was used to check a load cell Error.</p>

5-3 SERIAL INTERFACE

(RS-232C,CURRENT LOOP,RS-422/485)

SET BAUD RATE				
F30-	0	300 bps	5	9600 bps
	1	600 bps	6	14.4k bps
	2	1200 bps	7	19.2k bps
	3	2400 bps	8	28.8k bps
	4	4800 bps	9	38.4k bps

SET PARITY BIT		
F31-	0	EVEN
	1	ODD
	2	NO PARITY

SET TRANSMIT MODE		
F32-	0	Stream (Output in streams)
	1	Auto print (Output only when stable over 1% of full capacity)
	2	Print-key (Output only by pressing " Print " key)
	3	Output data when weight was finished
	4	Transmission COMMAND MODE
	5	Serial Printer mode only

SET FORMAT TRANSMIT DATA																																																	
F33-	0	<table border="1"> <tr> <td>S</td><td>T</td><td>.</td><td>N</td><td>T</td><td>.</td><td></td><td></td><td></td><td></td><td>k</td><td>g</td><td>(CR)</td><td>(LF)</td> </tr> <tr> <td></td><td></td><td></td><td></td><td></td><td></td><td></td><td></td><td></td><td></td><td></td><td></td><td></td><td></td> </tr> <tr> <td>Header1</td><td>Header2</td><td></td><td></td><td></td><td></td><td>WEIGHT(8)</td><td>UNIT</td><td></td><td></td><td></td><td></td><td></td><td></td> </tr> </table>	S	T	.	N	T	.					k	g	(CR)	(LF)															Header1	Header2					WEIGHT(8)	UNIT											
	S	T	.	N	T	.					k	g	(CR)	(LF)																																			
Header1	Header2					WEIGHT(8)	UNIT																																										
1	<table border="1"> <tr> <td>S</td><td>T</td><td>.</td><td>N</td><td>T</td><td>.</td><td></td><td></td><td></td><td></td><td>k</td><td>g</td><td>.</td><td></td><td>(CR)</td><td>(LF)</td> </tr> <tr> <td></td><td></td><td></td><td></td><td></td><td></td><td></td><td></td><td></td><td></td><td></td><td></td><td></td><td></td><td></td><td></td> </tr> <tr> <td>Header1</td><td>Header2</td><td></td><td></td><td></td><td></td><td>WEIGHT(8)</td><td>UNIT</td><td>TIME(6)</td><td></td><td></td><td></td><td></td><td></td><td></td><td></td> </tr> </table>	S	T	.	N	T	.					k	g	.		(CR)	(LF)																	Header1	Header2					WEIGHT(8)	UNIT	TIME(6)							
S	T	.	N	T	.					k	g	.		(CR)	(LF)																																		
Header1	Header2					WEIGHT(8)	UNIT	TIME(6)																																									
2	<table border="1"> <tr> <td>S</td><td>T</td><td>.</td><td>N</td><td>T</td><td>.</td><td></td><td></td><td></td><td></td><td></td><td></td><td>k</td><td>g</td><td>(CR)</td><td>(LF)</td> </tr> <tr> <td></td><td></td><td></td><td></td><td></td><td></td><td></td><td></td><td></td><td></td><td></td><td></td><td></td><td></td><td></td><td></td> </tr> <tr> <td></td><td></td><td></td><td></td><td></td><td></td><td></td><td></td><td></td><td></td><td></td><td></td><td></td><td></td><td></td><td></td> </tr> </table>	S	T	.	N	T	.							k	g	(CR)	(LF)																																
S	T	.	N	T	.							k	g	(CR)	(LF)																																		

* ID NO will be displayed automatically when setting of ID NO of F-90
 * No availabel in case fo F33 - 02

INSERT TRANSMIT DATA(STX)		
F34-	0	NO STX
	1	Transmition of STX(ASCII=02)

CONTROL INTERFACE WIRE/ RS422 (485)		
F35-	0	NO USE for CS, RS / in case of RS422,485
	1	USE FOR CS, RS

- ▶ WEIGHT (8)
 - SIGNAL (+ or -)
 - Weight (Included Decimal point)
- ▶ DATA For Number
 - 2B(H) “ + ” : PLUS
 - 2D(H) “ - ” : MINUS
 - 2O(H) “ ” : SPACE
 - 2E(H) “ . ” : Decimal Point
- ▶ Unit
 - k g : Unit of Kilrogram
 - t : Unit of TON
 - l b : Unit of Pound

■ RS-232C Circuit (25P D-Type Female Connector)

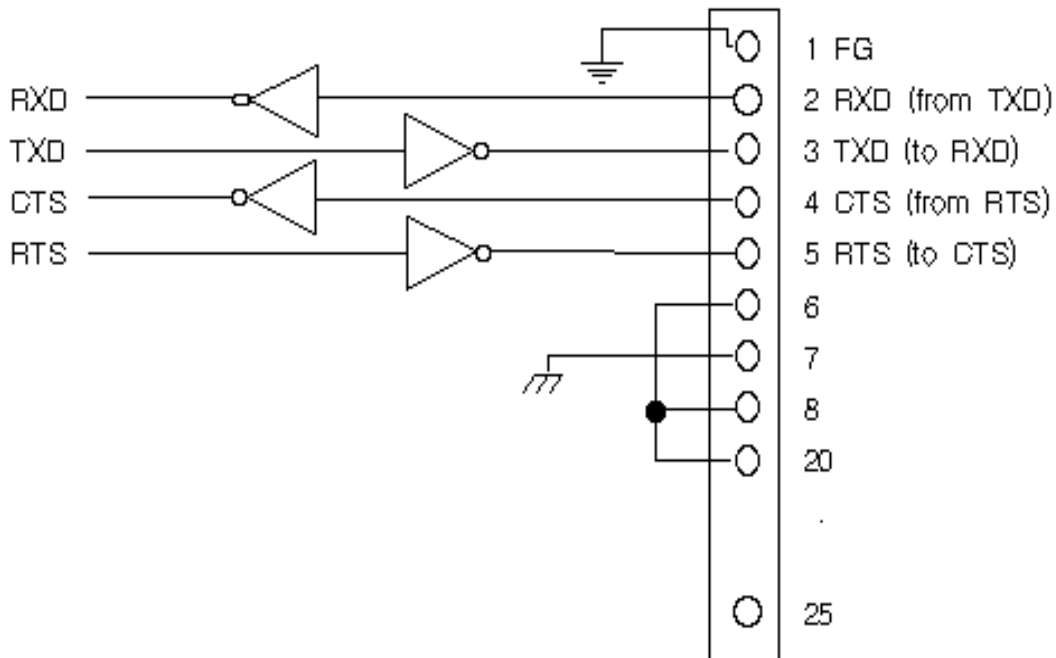

■ Receive Program example (Personal Computer)

F30-00, F31-00, F32-00, F33-00, F34-00

Basic Program

```

10 OPEN "COM1: 300, E, 7, 1, DS, CS" AS # 1
20 INPUT #1, A$, B$, C$
30 PRINT A$, B$, C$
40 GOTO 20

```

5-3-2. CURRENT LOOP (OP-02)

■ SINGAL FORMAT

0	20mA
1	0mA

Same as 5-1 RS-232 option

It must use the interface speed with 4800bps.

The distance recommended is 100 M and the resistance is 500 Ω

■ DATA FORMAT

Same as 5-1 RS-232 option

■ 25P D-Type Female Connector

* The transmission terminal was made with Non-polarity.

* The receive terminal was powered with 12V.

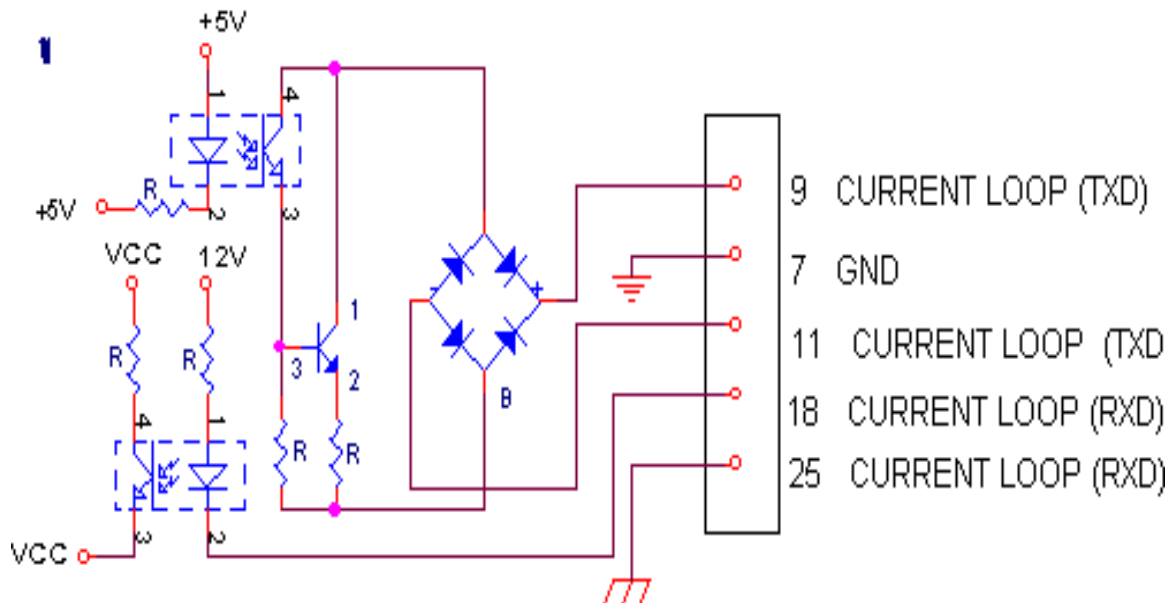

COMMAND MODE FORMAT

COMMAND	FUNCTION	RESPONSE	
		COMMAND MODE (F32-04)	Transfer Mode
R CR LF	demand current weight	Standard DATA FORMAT	No receive
T CR LF	Same as [TARE] Key	ACK CR LF	NO
KT 중량(6) CR LF	Same as [TARE] Key	ACK CR LF	NO
G CR LF	Change to ‘ Gross Weight	ACK CR LF	NO
N CR LF	Change to ‘ Net Weight	ACK CR LF	NO
Z CR LF	Same as [ZERO] Key	ACK CR LF	NO
P CR LF	Same as [PRINT] Key	ACK CR LF	NO
A CR LF	Same as [Sub-total] Key	ACK CR LF	NO
M CR LF	Remove Auto setting	ACK CR LF	NO
ST CR LF	Same as [Sub-total] Key	ACK CR LF	NO
GT CR LF	Same as [TOTAL] Key	ACK CR LF	NO
STC CR LF	Deleting Sub-total	ACK CR LF	NO
GTC CR LF	Deleting TOTAL	ACK CR LF	NO
HON CR LF	Setting HOLD	ACK CR LF	NO
HOF CR LF	Remove HOLD	ACK CR LF	NO
PN 품번(2) CR LF	Change PART	ACK CR LF	NO
CD 코드(6) CR LF	Setting CODE 6numerial	ACK CR LF	NO
DT YYMMDD CR LF	Setting DATE	ACK CR LF	NO
TI HHMMSS CR LF	Setting TIME	ACK CR LF	NO
RDT CR LF	Demend DATE	YY MM DD CR LF	No receive
RTI CR LF	Demend TIME	HH MM SS CR LF	No receive
RPN CR LF	Demend PART	PART(2) CR LF	No receive
RCD CR LF	Demend CODE NO	CODE (6) CR LF	No receive
RST CR LF	Demend Sub-total data	PART(2), FREQUENCY(6),WEIGHT(11) CR LF	No receive
RGT CR LF	Demend Total data	FREQUENCY(8) , WEIHTHT (13) CR LF	No receive
REN CR LF	Demend The last Weight	WEIGHT(7) CR LF	No receive

* F90- (01-99) : It should add to 2numerial of device ID no.

* F34- 01 : Starting will come to STX(ASCII=02).

5-4. SET-UP FOR CONTROLLING WEIGHT.

SET WEIGHING SYSTEM		
	0	Control Simple Comparison 1 (Limit Mode)
	1	Control Simple Comparison 2 (FALL)
	2	Control Simple Comparison 3 (LO-FALL,HI-FALL)
F40-	3	Control Simple Comparison 4 (Accumulation of 2 Materials)
	4	Sequence Control 1 (Packer Mode)
	5	Sequence Control 2 (Fall)
	6	Sequence Control 3 (LO-FALL,HI-FALL)
	7	Sequence Control 4 (Accumulation of 2 Materials)
	8	Control Weight Judgement1 (Checker Mode)
	9	Control Weight Judgement 2
	10	Control Weight Judgement 3

*** HIGH,LOW Judging Prohibition Time**

This Function is to delay Judging weight for the time set by F44 in case of a Vibration.

*** Weighing Range** : The range to weigh a final weight after prohibition time for HIGH weight judging.

- a) Manual Weighing : Total weight in inputting printer key **F46-00**.
- b) Steady : Total weight when it was steady **F46-01**
- c) Steady & Time : Total weight after a general time for the above (b) **F46-02**.
- d) Time : Total weight after time set by **F41**

*** ZERO/TARE INPUT**: Function to keep ZERO the present weight before weighing.

***EMPTY Signal**: It occurs a empty signal when the weight of a weighing part was less than.

- **F13** : SET EMPTY MODE
- **F14** : SET EMPTY SIZE when **F13-02,F13-03**.
- **F15** : SET weight Comparison (Display Weight, Basic ZERO)
Recommand **F15-01(Basic ZERO)**.

*** FINISH Signal** : **ON** in weighing and **OFF** after Time set by **F42**

5-4-1 Control Simple Comparison 1 SET

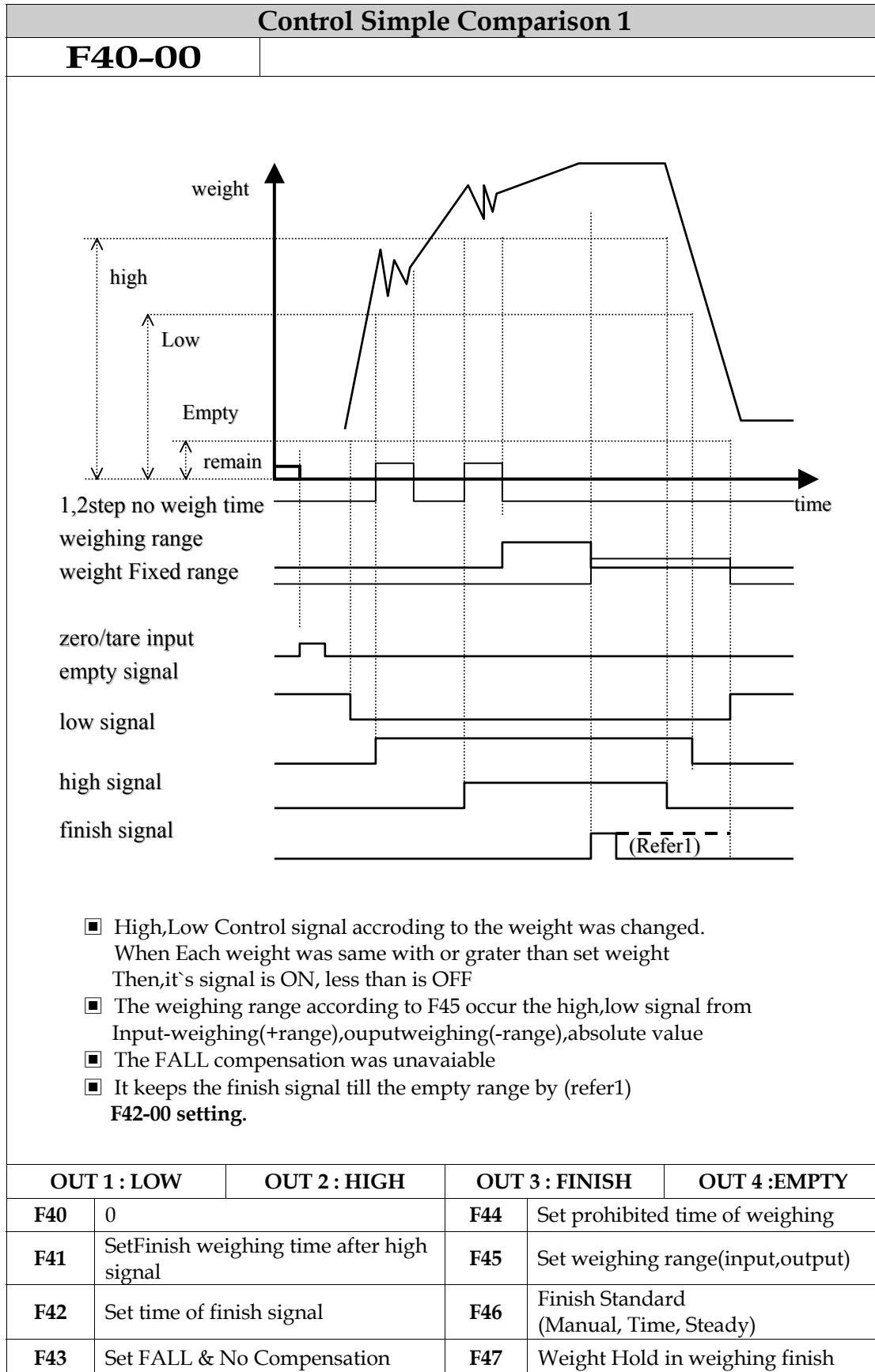

5-4-2 Control Simple Comparison 2 SET

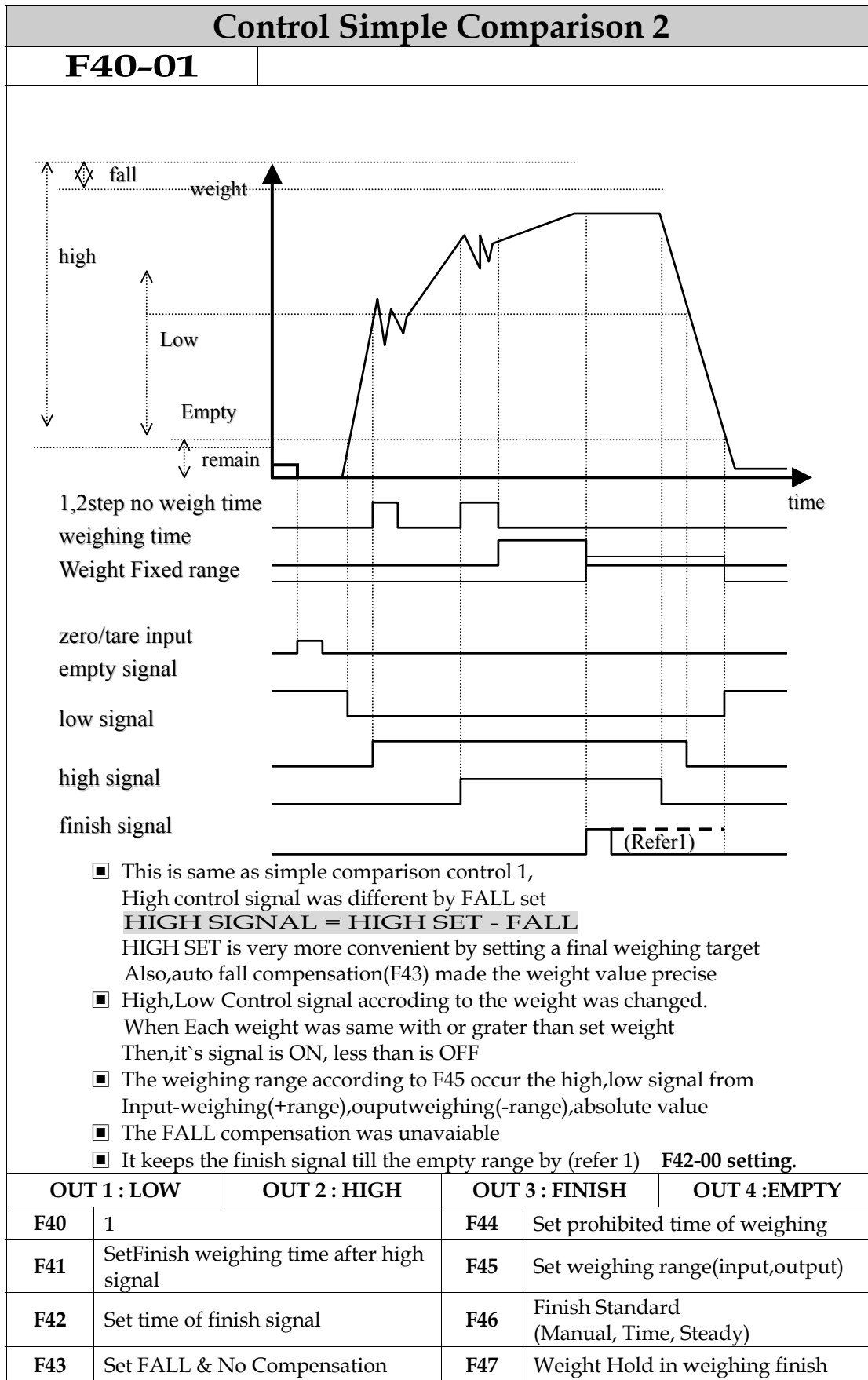

5-4-3 Control Simple Comparison 3 SET

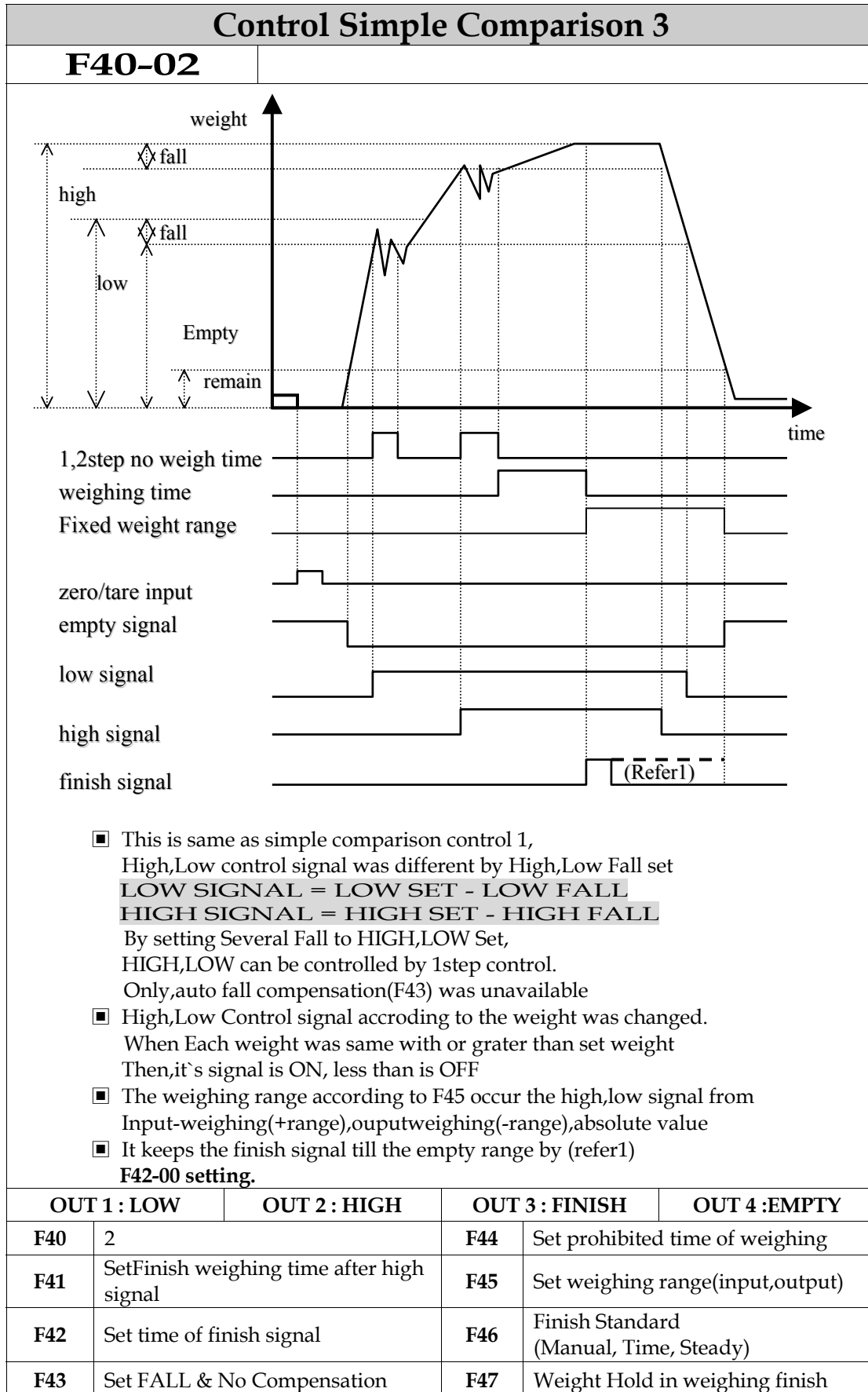

5-4-4 Control Simple Comparison 4 SET

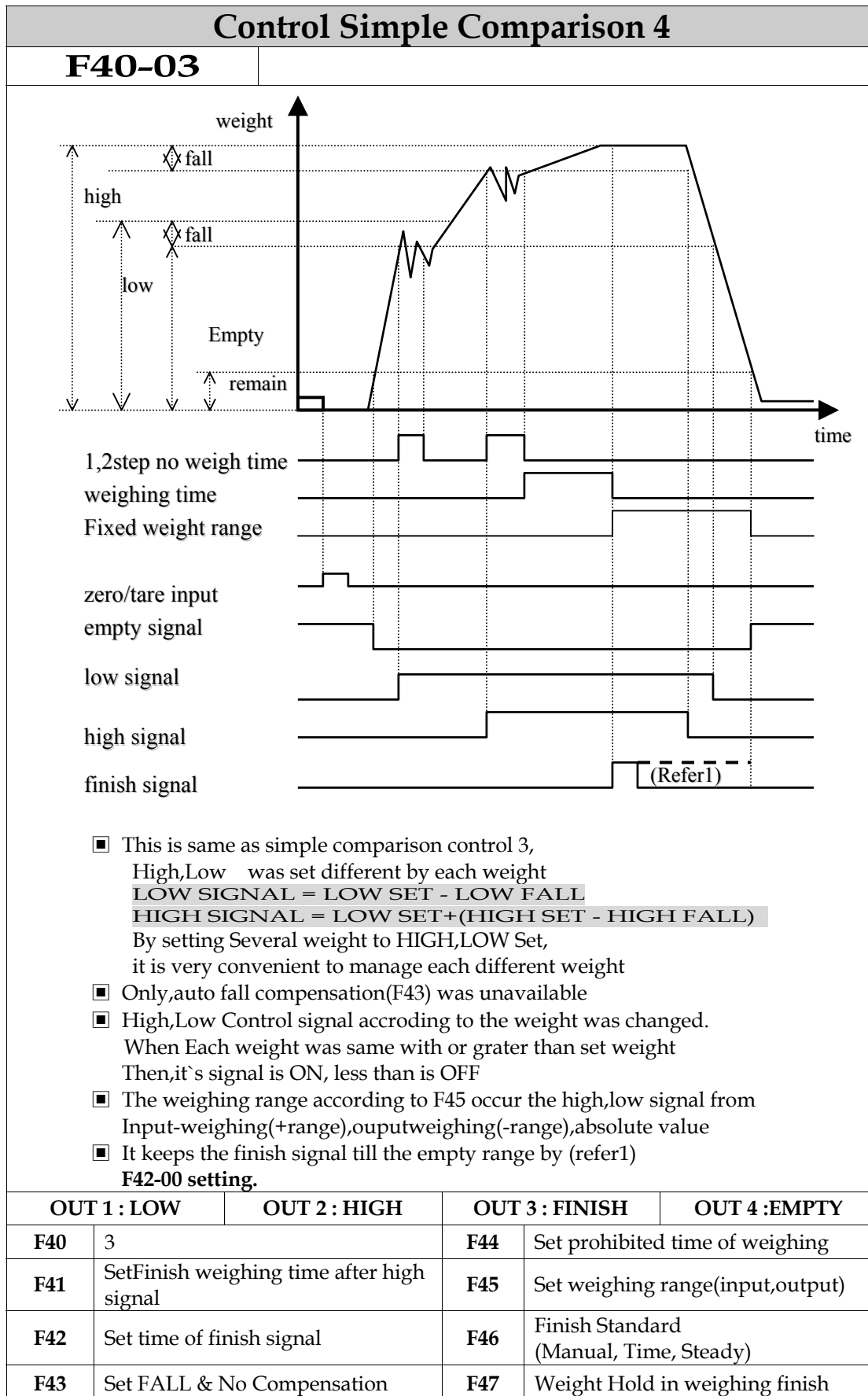

5-4-5 Sequence Control 1 set

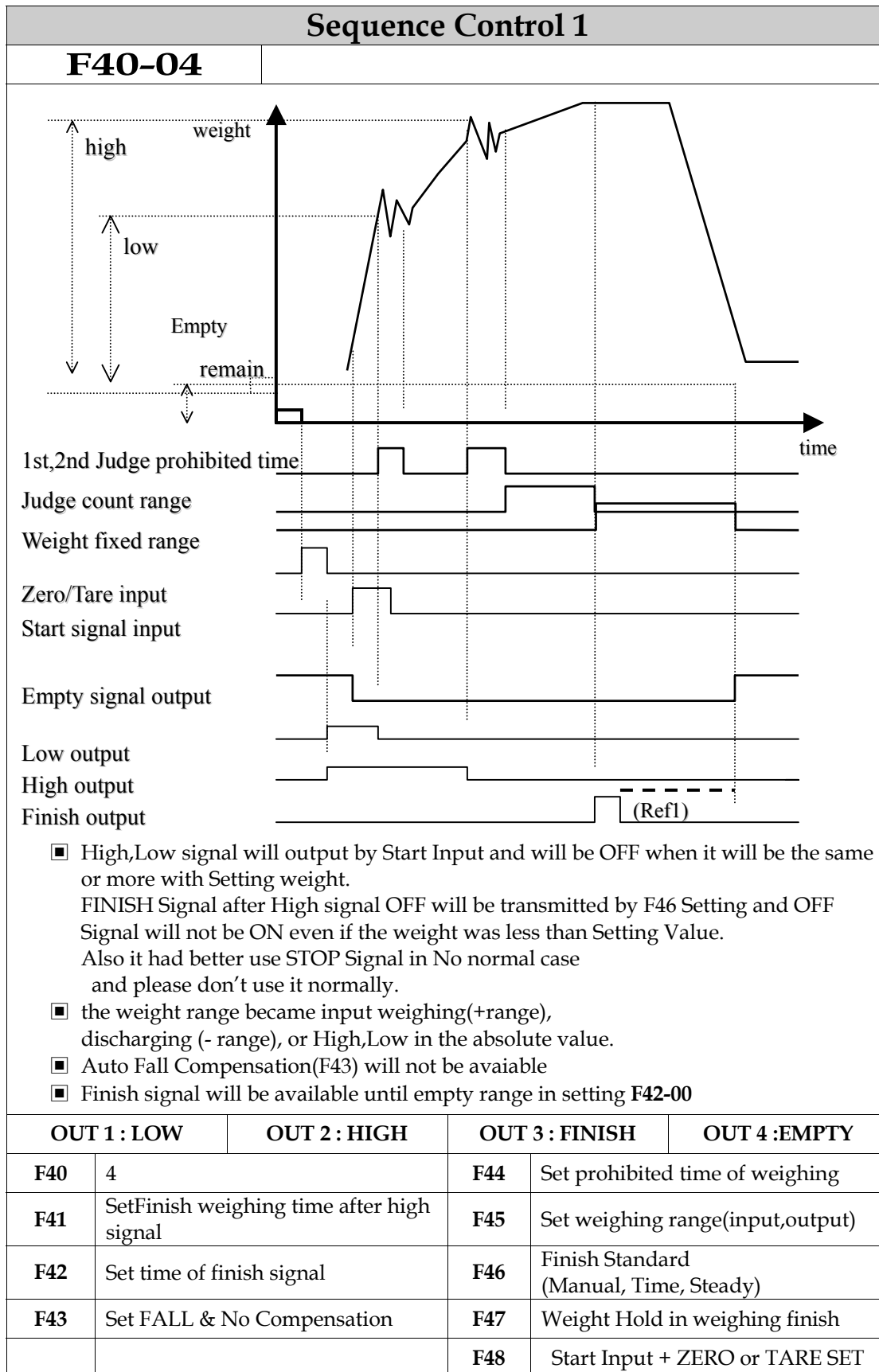

5-4-6 Sequence Control 2 set

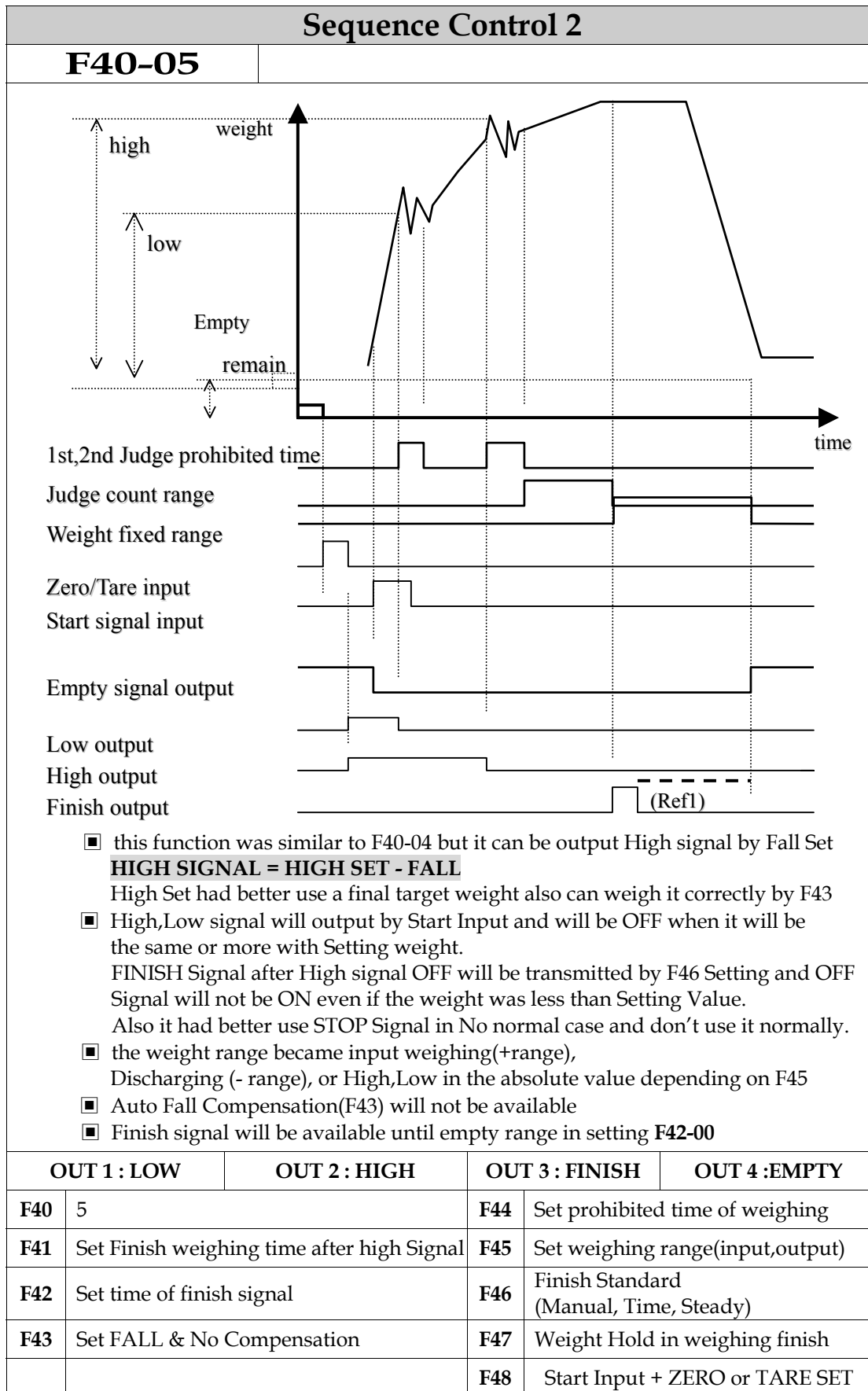

5-4-7 Sequence Control 3 set

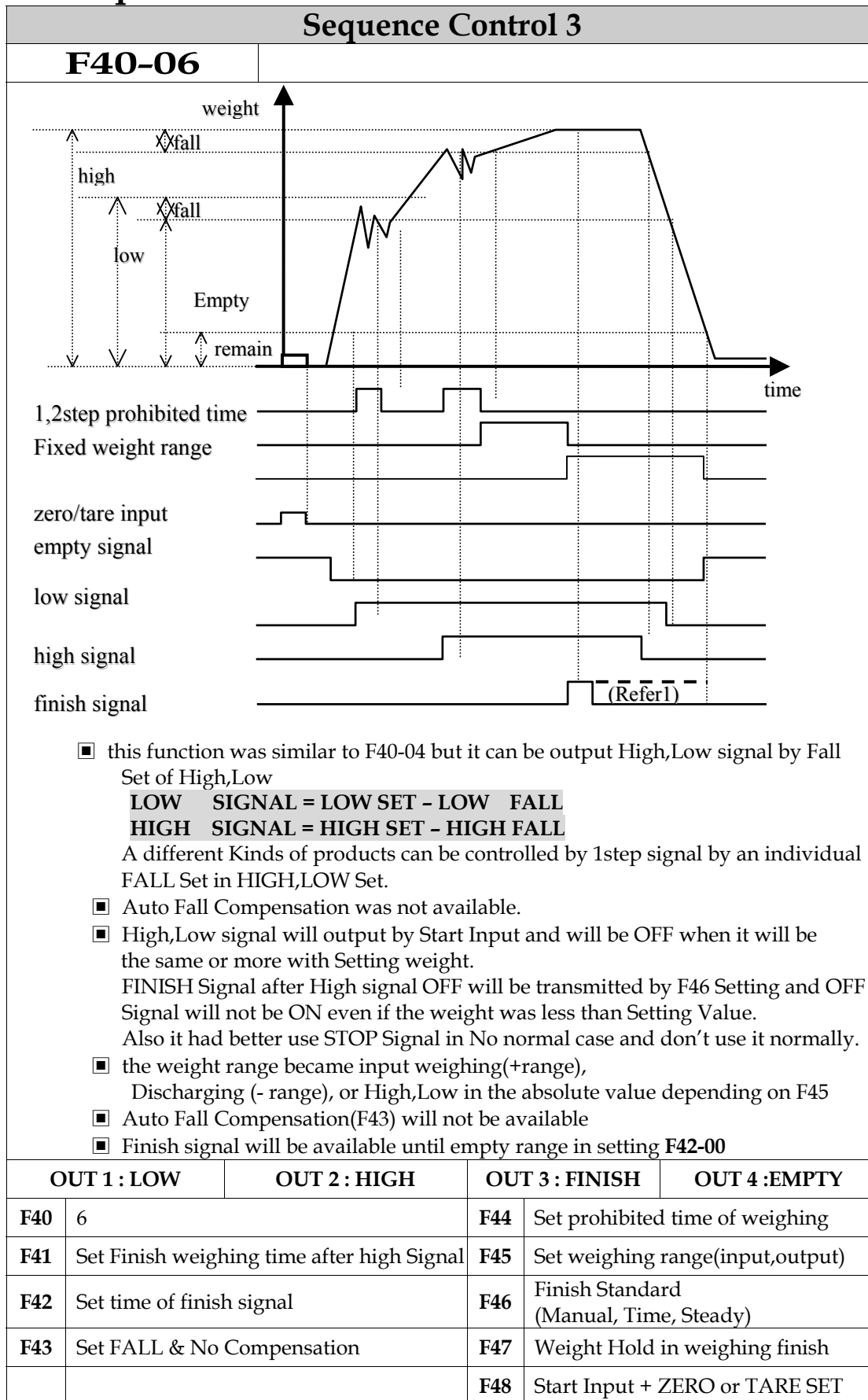

5-4-8 Sequence Control 4 set

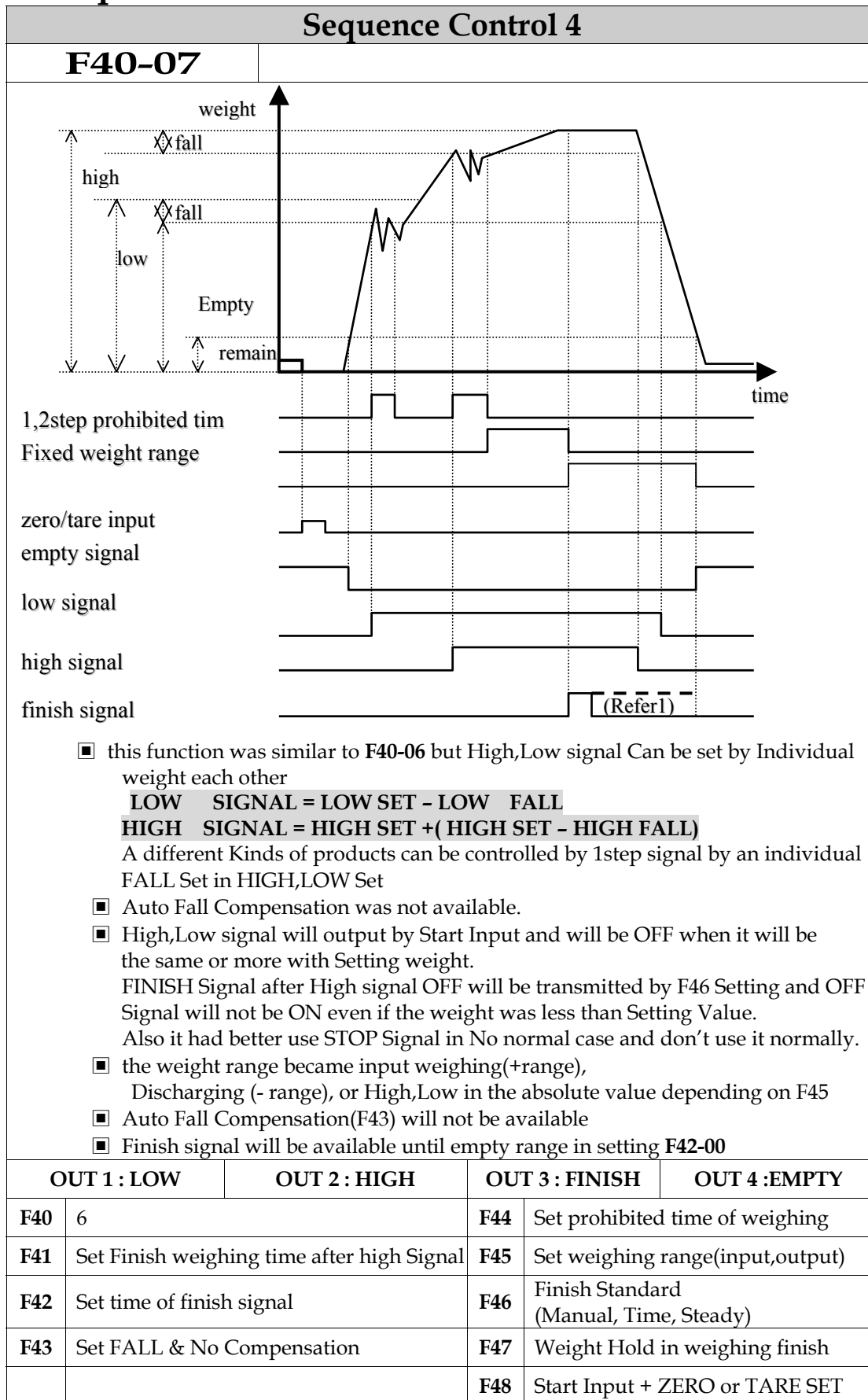

5-4-8 Check Mode Control 1 set

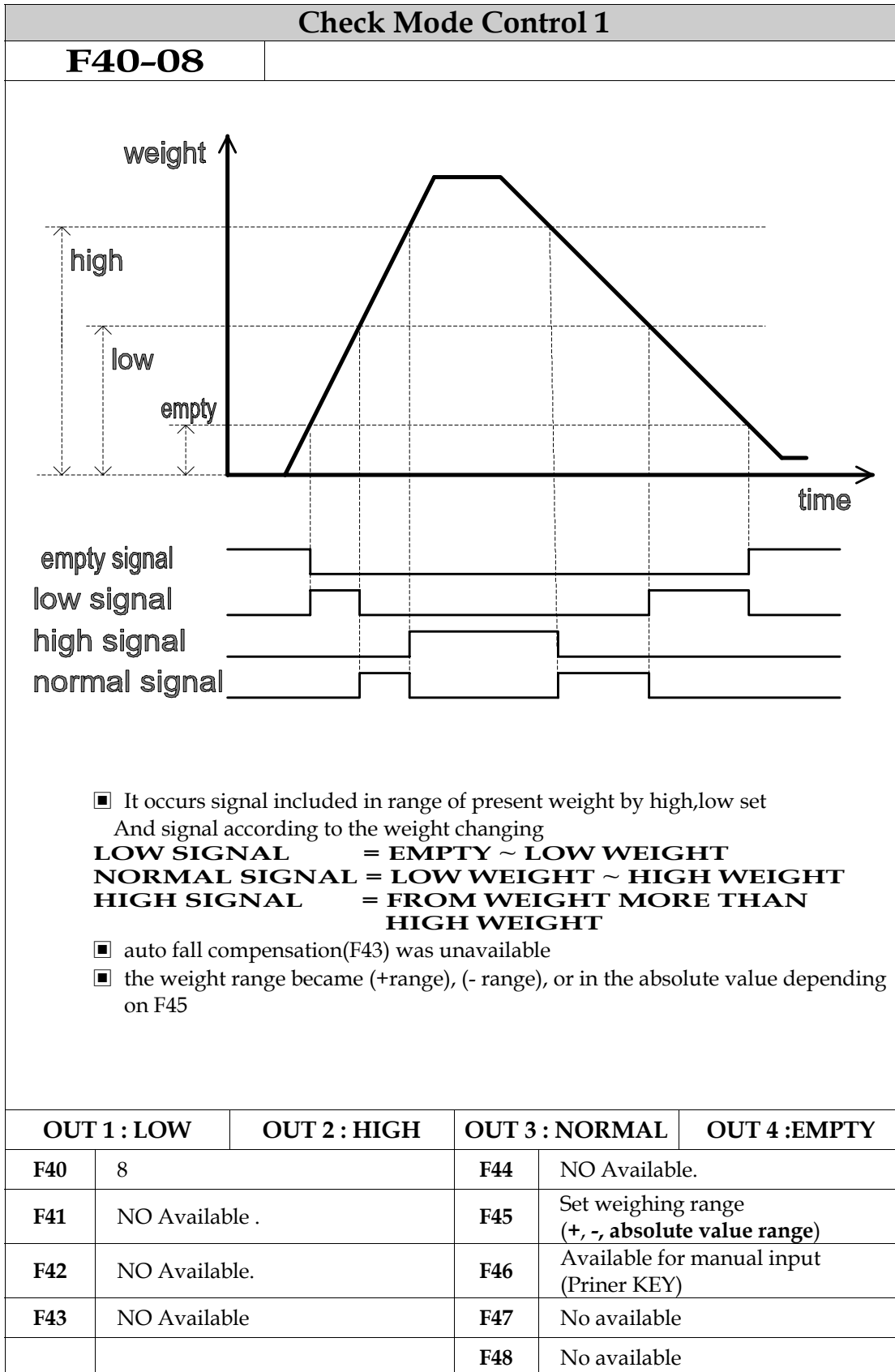

5-4-10 Check Mode Control 2 set

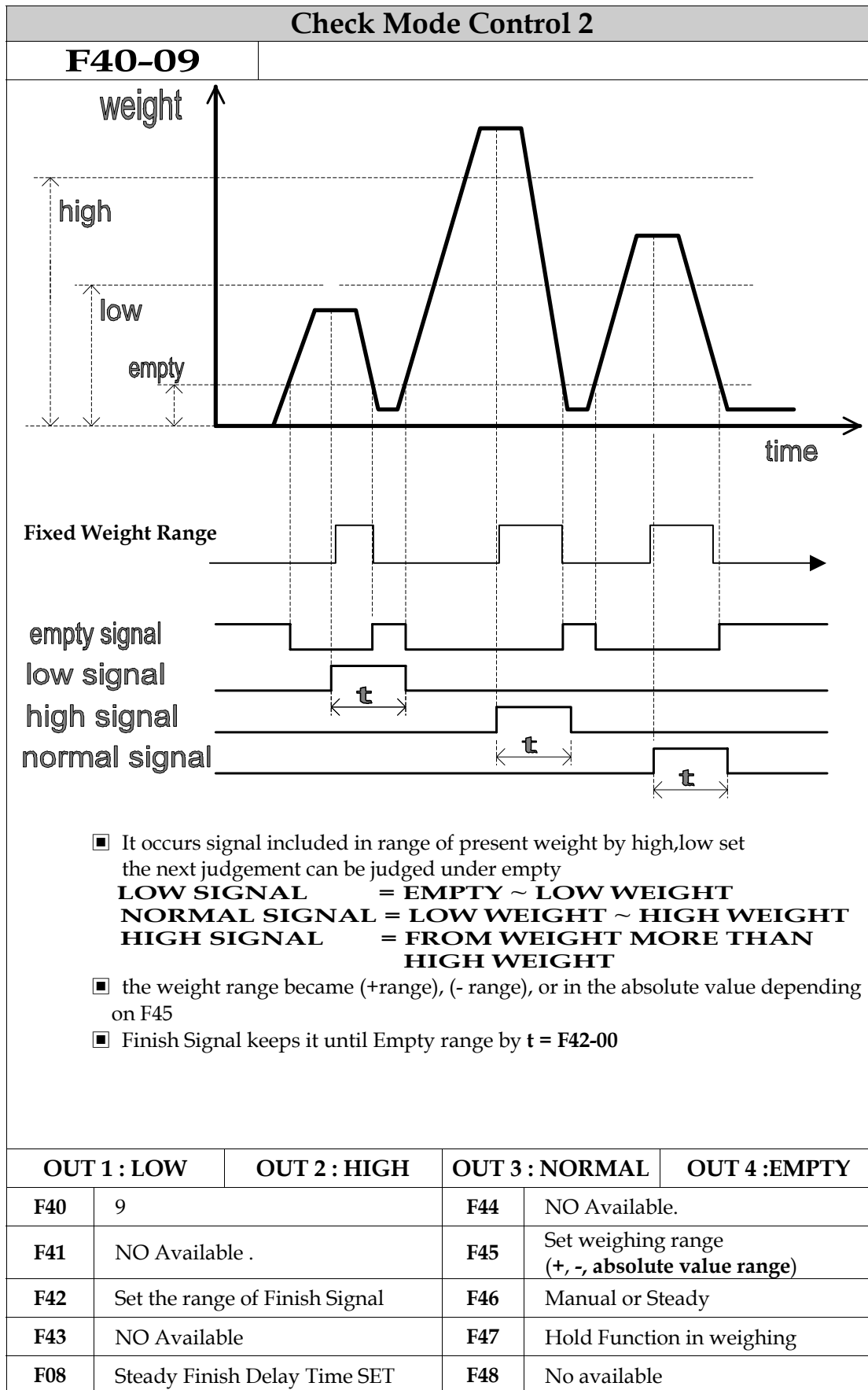

5-4-10 Check Mode Control 3 set

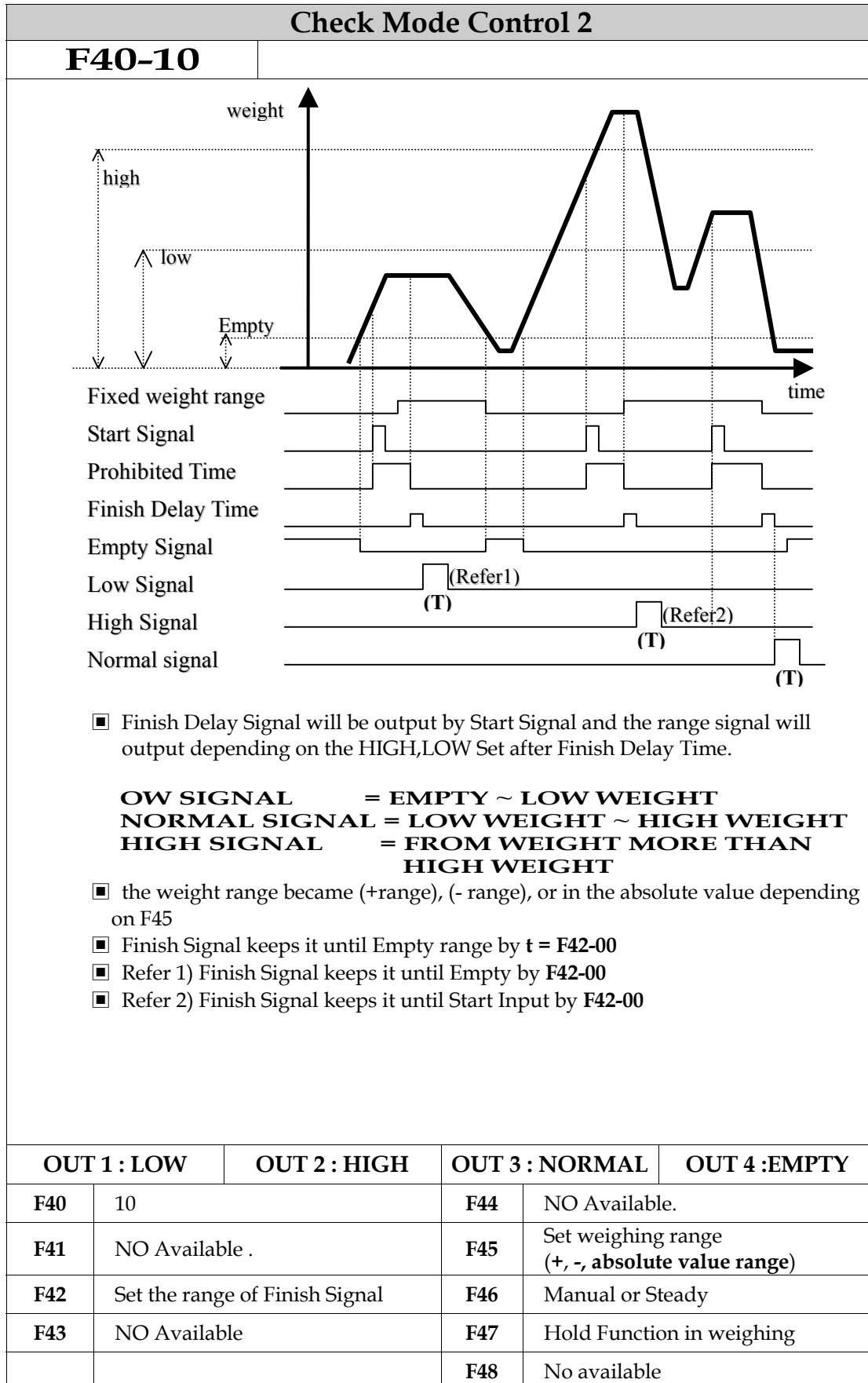

Delay time for End Judgement		
F-41	0 ~ 99	This is the delay time for the weighing judgement after the final setting value is operated. 0 = 0 sec 1 = 0.1 sec 99 = 9.9 sec *First Setting : 10(1sec)

Maintaining time for End judgement		
F-42	0 ~ 99	Set the maintaining time of End judgement signal. 0 = Continuous maintaining 1 = 0.1 sec 99 = 9.9 sec *First Setting : "00"(Continous)

Function SETTING For FALL COMPANSTION		
F-43	0	NO FALL COMPENSATION
	1	80% FALL COMPENSATION WITH 5Times
	2	90% FALL COMPENSATION WITH 10Tmes
	3	90% FALL COMPENSATION WITH 20Times
	4	100% FALL COMPENSATION WITH 50Times
Fall Compensation will not be available if setting weight was over $\pm 10\%$ range		

Setting for Judge Prohibited Time		
F-44	0 ~ 99	Judement will not be done for this function setting time after 1 st ,2 nd Relay. *First Setting : "03"(sec)

SETTING For a weighing Range		
F-45	0	" + " only Control Signal possible
	1	Absolute Value Control Signal Possible
	2	" + " only Control Signal possible

SETTING For Finish Judgement system

F-46	0	Printer key
	1	Finished Signal by Safe Signal
	2	Finished Signal by Safe Signal or F41
	3	Finished Signal by F41
Automatic Higtogram when Finish Relay work		

SETTING For Finish Display system

F-47	0	Display for weight change
	1	Empty Signal or Start Signal

SETTING ZERO ,TARE WHEN START TO IINPUT

F-48	0	No Function
	1	ZERO setting by F07 only
	2	Setting TARE

5-5. Additional Set-up Function

5-5-1 OP - 03 BCD OUTPUT

BCD OUTPUT Weight Selecting		
F50-	0	Displayed Weight Value
	1	GROSS Weight
	2	NET Weight

BCD OUTPUT POLARITY		
F51-	0	Positive Logic
	1	Negative Logic

■ Connected Pin drawing

PIN NO	SIGNAL
1	GROUND (GND)
2	1×10^0
3	2×10^0
4	4×10^0
5	8×10^0
6	1×10^1
7	2×10^1
8	4×10^1
9	8×10^1
10	1×10^2
11	2×10^2
12	4×10^2
13	8×10^2
14	1×10^3
15	2×10^3
16	4×10^3
17	8×10^3
18	1×10^4
19	2×10^4
20	4×10^4
21	8×10^4
22	1×10^5
23	2×10^5
24	4×10^5
25	8×10^5

PIN NO	SIGNAL
26	Hi : Net LOW : Gross
27	
28	
29	
30	
31	
32	
33	
34	
35	
36	
37	EX. Vcc
38	
39	EX. Vcc
40	
41	
42	Hi : Positive Polarity
43	Decimal Point 10^1
44	" 10^2
45	" 10^3
46	
47	OVER LOAD
48	
49	BUSY
50	HOLD (INPUT)

- ▶ 50 PIN CONNECTOR: CHAMP 57-40500(Ampheonol) (Female)
- ▶ TTL OPEN-COLLECTOR OUTPUT
- ▶ HOLD INPUT should be connected with OPEN COLLECTOR TYPE or Switch Earth.
- ▶ And OUTPUT DATA will hold while HOLD INPUT

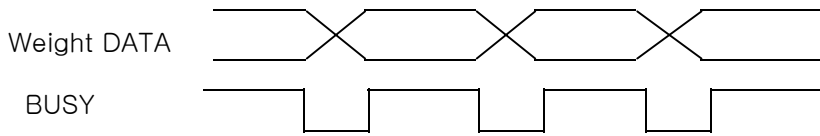

- Signal Logic
- ① Weight BCD DATA OUTPUT → Positive)/Negative .
 - ② POLARITY OUTPUT → " - " = L
 - ③ OVER → " OVER " = L
 - ④ BUSY → " BUSY " = L
 - ⑤ BCD HOLD → " HOLD " = L (INPUT)

■ BCD OUTPUT CIRCUIT

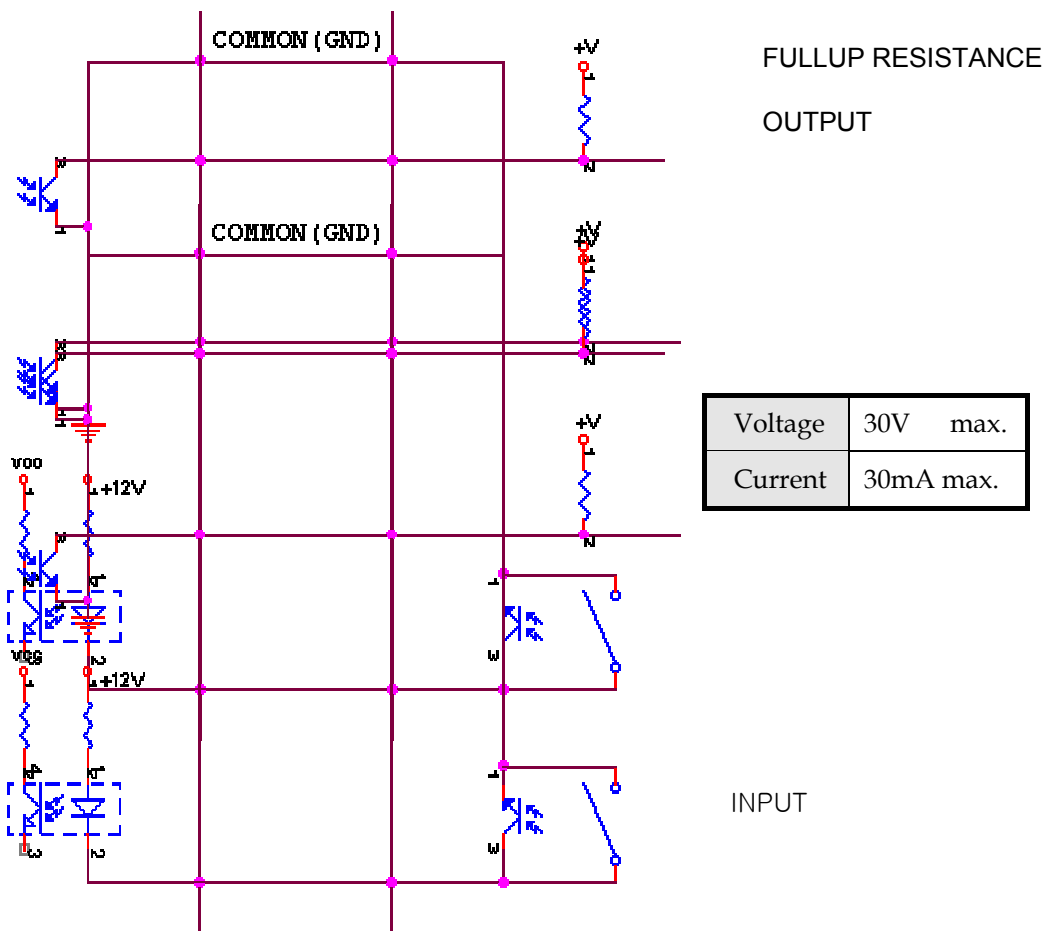

- OUTPUT CIRCUIT IS OPEN COLLECTOR TYPE
- If output demand TTL LEVEL ,insert full up - resistance to a borad of BCD OPTION
- When inserting a fullup resistance ,please change 5v ~ 30V in **37,39 NO**
- Resistance and Voltage .
 $5V = 1\text{ k}\Omega$, $10V = 2\text{ k}\Omega$, $15V = 2.7\text{ k}\Omega$, $24V = 5\text{ k}\Omega$

5-5-2 OP-04 RS-422 / 485 Serial Interface

- RS-485 should be connected as follows.

RXD(+) + TXD(+), RXD(-) + TXD(-)

- Recommended distance is under 1.2 km .

▣ SIGNAL FORMAT

① TYPE : RS-422/485

② FORMAT : (a) Baud-Rate : 300 ~ 38.4k .

(b) Data Bit : 7 or 8 (NO Parity)

(c) Stop : 1

(d) Parity Bit : Even, Odd, NO Parity select.

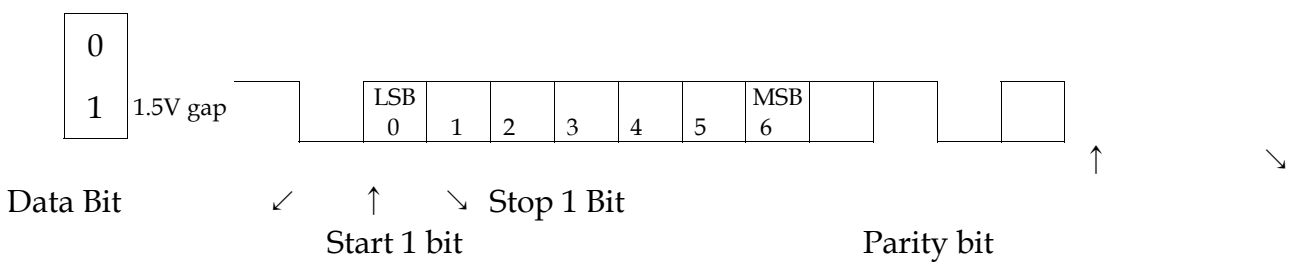

▣ DATA FORMAT

* Same as RS - 232C

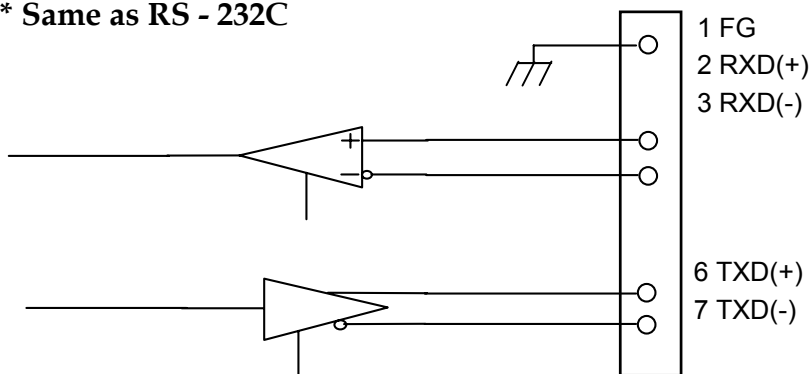

RS-422 / 485 Circuit (9P D-Type Female Connector)

5-5-3 OPTION-05,06 ANALOG OUT

Analog Out Weight Selecting		
F60-	⓪	displayed Weight value
	1	GROSS Weight
	2	NET Weight
Gross or Net Weight can be different with weight value displayed		

Analog Out POLARITY		
F61-	⓪	Max. Weight Standard
	1	Standard value setup by F-63

Analog Out POLARITY		
F62-	⓪	Positive out : 4mA, 0V while weight is 0
	1	Negative out : 20mA, 5V, 10V while weight is 0

Analog Out Standard Weight Selecting.	
F63-	Analog max out value when weight setup. * <u>first Setting 000000</u>

5-5-3-1 OP-05 voltage (0~10V) Analog out

This option is used to be transmitted the voltage out, which is changed from weight value, to external devices like recorder P.L.C. and analog signalled equipments.

■ SPECIFICATION

output Voltage	0 ~ 10V DC out
Precision	Max 1/3000
Min Impedence	Over 1 kΩ

■ 9P D-TYPE Female) & Voltage out circuit

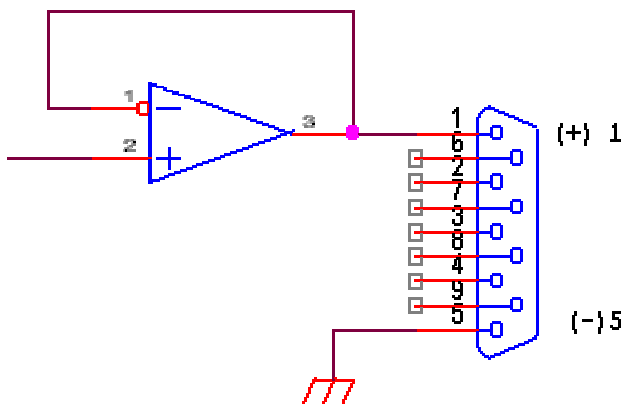

* How to calibrate for output rate between 0v and 10v.

■ Adjustment

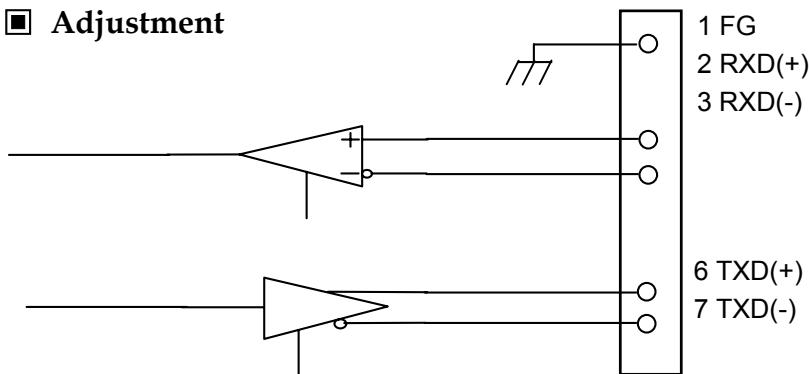

* The voltage out is to 0V when the weight is displayed 0 kg in indicator.

* The voltage out is to 10V when the weight is displayed max.capacity in indicator.

* If analog output is not correct,

You can make a fine adjustment with VR1(Zero adjustment) and VR2(Span adjustment) on analog pc board by multi meter.(Recommended accuracy : 1/3,000)

5-5-3-2 OP -06 Electric(al) current (4~20mA) Analog Out

This option is used to be transmitted the current out, which is changed from weight value, to external devices like recorder P.L.C. and analog signalled equipments.

■ Specification

output Voltage	4 ~ 20 mA DC Current out
Precision	Max 1/3000
Min Impedence	Under 500 Ω

■ 9P D-TYPE Female & Current out circuit

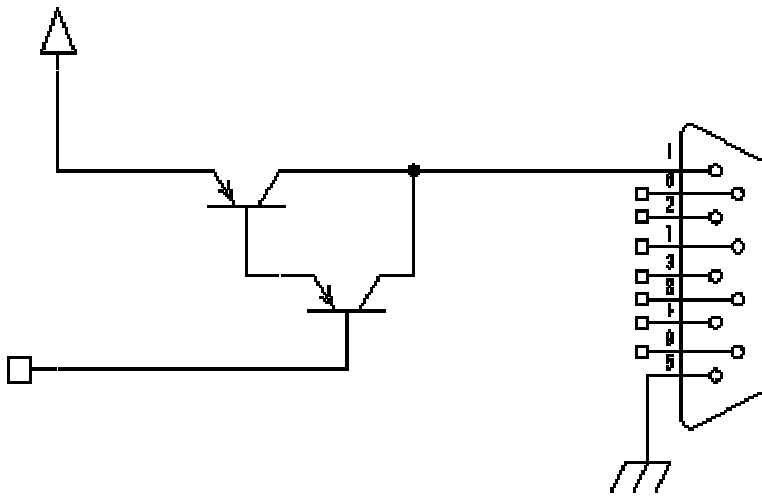

* The resistor must be used with enough power consumption.

If you used 500 ohm resistor,

$$W = i^2R = (0.02)^2 \times 500 = 0.2 \text{ Watt}$$

So, the rate of resistor must be used over than 1/2 watt by 0.2 watt power consumption.

* **Absolutly do not connect above Lo(-) line to GND line, body GND Or any similar devices. Because it is -12V, not ground (0V).**

* **How to calibrate for output rate bewteen 4mA and 20mA.**

The current out is to 4 mA when the weight is displayed 0 kg in indicator.

The current out is to 20 mA when the weight is displayed max.capacity in indicator.

If analog output is not correct,

You can make a fine adjustment with VR1(zero adjustment) and VR2(span adjustment)

On analog pc board by multi meter.

5-5-4. OP-07 PRINTER

This option have serial interface and centronics parallel typies.
 It will be able to connect another printers which are used by serial interface or Centronics parallel type

PRINTER SELECTING		
F71-	Ⓞ	PRITNT SHEET 0
	1	PRTINT SHEET 1

PRINT SHEET 0		
=====		
DATE :	1999-01-01	
TIME :	12:35:07	
CODE :	123456	
SERIAL	PART	WEIGHT
1	1	1.000 kg
2	1	1.100 kg
3	1	1.200 kg
4	1	0.900 kg
5	1	1.000 kg
=====		
SUB-TOTAL		
START :	1998-12-30 8:12	
END :	1999-01-01 14:26	
PART :	01	
CODE :	123456	
COUNT =	5	
WEIGHT =	5.200 kg	

PRINT SHEET 1		
=====		
DATE :	1999-01-01	
TIME :	12:35:07	
CODE :	123456	
SERIAL	PART	WEIGHT
1	1	1.000 kg
=====		
DATE :	1999-01-01	
TIME :	12:35:07	
CODE :	123456	
SERIAL	PART	WEIGHT
2	1	1.000 kg
=====		
SUB-TOTAL		
START :	1998-12-30 8:12	
END :	1999-01-01 14:26	
PART :	01	
CODE :	123456	
COUNT =	2	
WEIGHT =	2.000 kg	

PRINTER PAPER QUANTITY WHEN FINISHING		
F72	0 ~ 99	1 LINE PRINT OUT PER 1COUNT(LINE FEED) * FIRST SET-UP 00

SUB TOTAL PRINTER MODE		
F73	0	SUB TOTAL PRINT SHEET 0
	1	SUB TOTAL PRINT SHERT 1

Sub-total PRINT SHEET 1
=====
SUB-TOTAL
START : 2000-03-28 12:34
END : 2000-03-29 9:50
PART : 1
CODE : 123456
COUNT : 10
MIN : 9.998 kg
MAX : 10.002 kg
AVG : 10.000 kg
=====

Sub-total PRINT SHEET 0
=====
SUB-TOTAL
START : 2000-03-28 12:34
END : 2000-03-29 9:50
PART : 1
CODE : 123456
COUNT : 10
WEIGHT : 100.000 kg
=====

☒ 25P D-Type Female Connector

PIN NO.	Contents
14	N.C
15	N.C
16	N.C
17	N.C
18	GND
19	N.C
20	N.C
21	N.C
22	N.C
23	N.C
24	N.C
25	N.C

PIN NO.	Contents
1	STROBE
2	D0
3	D1
4	D2
5	D3
6	D4
7	D5
8	D6
9	D7
10	ACK
11	BUSY
12	N.C
13	N.C

5-5-5. OP-10 BCD INPUT.

* Recommend distance is under 10 M .

* In case PART 19 displayed with BCE CODE such as 0001 10001

0 = OFF, 1 = ON

■ 15P D-Type Female Connector

PIN NO	SIGNAL
1	1×10^0
2	2×10^0
3	4×10^0
4	8×10^0
5	1×10^1
6	2×10^1
7	4×10^1
8	8×10^1

PIN NO	SIGNAL
9	EARTH (GND)
10	
11	AID INPUT 1
12	AID INPUT 2
13	AID INPUT 3
14	AID INPUT 4
15	EARTH (GND)

■ BCD INPUT CIRCUIT

